

If you need more information on Computer and Electronic Repair, please visit these websites to improve yourself.

<http://www.fastrepairguide.com>

<http://www.protech2u.com>

<http://www.plasma-television-repair.com>

<http://www.lcd-television-repair.com>

Happy Repairing!!

### **Highly Recommended Repair Ebook:**

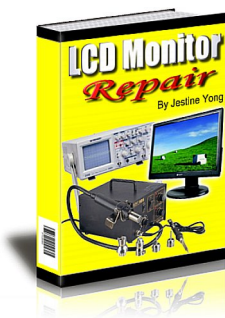

If you're a LCD Monitor repairer, then this is the best guide for you. Why? Because, the author revealed all his LCD Monitor Repairing secrets for you. I think, with just few Repair tips you learned from this guide you will get back your investment!

[Click Here to read](#) more.



This eBook will show you how to test the electronic component correctly and accurately. Some of you may say that I don't need this eBook because it is too simple! Do you know that, in fact there is lots of testing electronic components secrets I have learned from this guide? Do you know how to test a 'TRIAC' correctly and accurately? If you answer no then I guess you have to get this eBook. [Click Here to read more.](#)

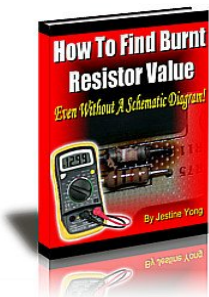

Are you tired of searching the service manuals to look for the value of a burnt resistor? If the answer is YES, then this eBook is a 'must have' guide for you. You can save a lot of time and be able to repair customer's Electronic equipment with burnt resistors in it.

[Click here to read more.](#)

# **COLOUR TELEVISIONS**

**15 inch LCD TV  
Service Manual**



## **CONTENTS**

## **PAGES**

<b>Safety instructions</b>	<b>1</b>
<b>Technical specifications</b>	<b>2</b>
<b>Instruction manual</b>	<b>3</b>
<b>Interconnection Guide</b>	<b>14</b>
<b>Block diagram</b>	<b>15</b>
<b>Data sheet of important IC's and parts</b>	<b>16</b>
<b>Service Mode and Adjustments</b>	<b>31</b>
<b>Waveforms</b>	<b>33</b>
<b>Part List</b>	<b>36</b>
<b>Frequency list of channels</b>	<b>38</b>

# SAFETY PRECAUTIONS

## GENERAL GUIDELINES

1. Always use the manufacturer's replacement safety components. The critical safety components marked with ∇ on the schematics diagrams should not be by other substitutes. Other substitute may create the electrical shock , fire or other hazards. Take attention to replace the spacers with the originals. Furthermore where a short circuit has occurred , replace those components that indicate evidence of overheating.
2. After servicing , see that all the protective devices such as insulation barriers, insulation papers, shields and isolation R-C combinations are correctly installed.
3. When the receiver is not being used for a long time of period of time , unplug the power cord of the Adaptor from the AC outlet.

*Color TFT LCD Module is very sensitive both electrically and physically. Users, therefore, are requested to follow the "Guidance of handling color TFT LCD Module" on the followings.*

**1 - Be careful not to make scratch on the polarizer.**

Surface of polarizer is soft and can be physically damaged easily.

Please do not touch, push or rub polarizer surface with materials over HB hardness.

**2 - Keep clean the surface.**

Please wear rubber glove when touch the surface of LCD screen. Please use soft and anti-static material as cleaner.

**3 - Keep out of water.**

Water on/in the LCD may cause electrical short or corrosion. Please wipe out dry or water carefully.

**4 - Prevent swift Temperature & Humidity change.**

Instantaneous temperature and/or humidity change can make dew or ice which cause nonconformance such as malfunction.

**5 High temperature & high humidity reduce the life-time.**

LCD is not proper to be used at high temperature and high humidity. Please keep specified temperature and humidity condition.

**6 - Keep out of Corrosive Gas.**

Corrosive gas effect the polarizer and the circuit chemically and cause defects accordingly.

**7 - Electrostatic discharge can make Damage**

There are electro-static sensitive components such as CMOS in LCD Module. Please earth human body when handle the LCD. In addition, please do not touch the interface connector pin with bare.

**8 - Do not operate for a long time under the same pattern**

Operating LCD for a long time under the same pattern can cause image persistence and can damage it. Please follow following guidance.

1. Turn the power off when do not use.
2. Change the pattern periodically.

## TECHNICAL SPECIFICATIONS

Power source	12VDC , 3.5A	
	Adaptor input 100-250VAC 50/60Hz	
Aerial Impedance	75Ohm, Coaxial Type	
Receiving System	PAL SECAM BG	
	PAL SECAM BG DK	
	PAL I	
	PAL SECAM BG LL'	
	NTSC (4.43,3.58) tru Scart	
Receiving channels	VHF I Band, CH2-4	
	VHF III Band, CH5-12	
	CABLE Band, S1-S41	
	UHF Band, CH21-69	
TFT LCD Panel	Screen diagonal	15.1 inch
	Display area	304.1(H) X 228.1(V) mm
	Number of Pixel	1024 X 768 Pixel
	Display Colors	16.2 million color
	Response Time	25ms (typ.)
	Contrast ratio	450:1 (250:1 optional)
	Brightness	450 (250 optional)Cd/m2
	Viewing angle	80h / 70v
	Pixel pitch	0.6375 mm X 06375 mm
	Back Light	6 CCFT
Teletext	Text, Fasttext, Toptext	
	Page memory 100	
External Connections	Standard VGA Connector	VGA resolution, 56-85Hz Vertical
	AV1 (AV in-out and RGB connection)	
	AV2 (AV in-out)	
	AV3 (AV input from cinch connector)	optional
	AVS (SVHS input)	optional
	Audio line outputs (cinch connector)	
Audio Outputs	2X3W RMS Audio output (at %10 THD)	
	Stereo Headphone	
	A2 stereo, Nicam	
Power Consumption	70W	
	2.5W at Stand by	

# Getting started

Remove your Television carefully from the box. You may wish to store the packaging for future use.

## In the box

Inside the cartoon box you should have:

- Accessories box
- Power cord
- Adapter
- Remote control
- Batteries

Read these instructions before use.

## Aerial connection

To connect an aerial, plug the aerial lead into the aerial socket on the rear of the TV.

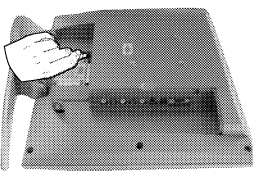

You can use an outdoor or indoor aerial. However, if you use an indoor aerial the quality of the reception may be reduced and adjustment of the aerial may be required when changing programs.

### Please note

If you live in a poor reception area or use an indoor aerial you may experience loss or corruption of teletext transmissions.

## Switching on and First Use

1. Connect the power cord to the mains plug.
2. Connect the input socket of the adapter to the 12 V DC socket at the back panel of the LCD TV.
3. Connect adapter to the mains plug.

**Note 1:** Your TV will move to stand-by mode in five minutes when there is no broadcast signal.

**Note 2:** Your TV is equipped to operate with front panel buttons, "MENU", "PR+", "PR-", "4+", "4-", in case your R/C is broken or you run out of batteries.

### Please Note

When not in use disconnect the plug from the mains power supply.

4. Press the **Power** button on the front of the TV. The standby indicator will illuminate.
5. Press a **Numeric** button or the **Program up** or **Program down** button on the remote handset or **Program up**, **Program down** or **MENU** button on the front panel to switch the TV on.

The standby indicator remains on. The picture will appear after a few seconds.



Press the **Standby** button to switch the TV to standby. The standby indicator will brighter.

### Please Note

Do not leave the television on standby unattended or overnight.

### Switching the TV on for the first time

To install your TV, please read the sections "TV controls" and "Tuning the television".

## Battery fitting

Insert the 2 AAA Batteries supplied into the compartment on the rear of the remote control, ensure you follow the polarity diagram inside the compartment.

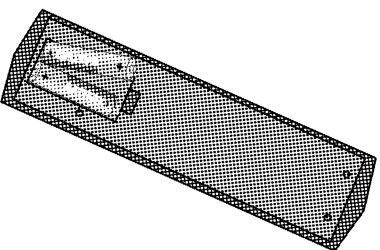

# Control Unit

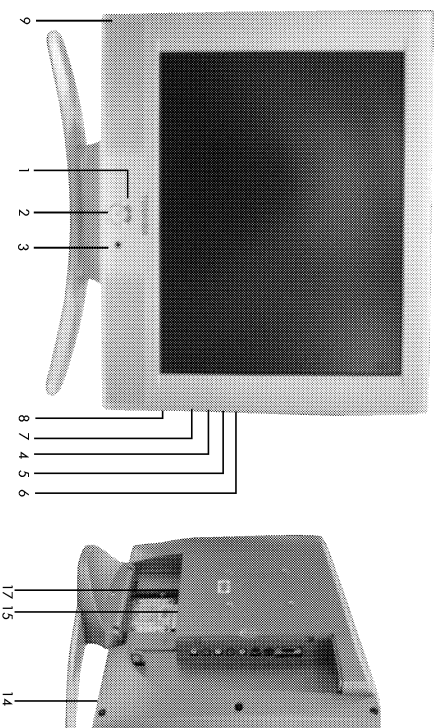

1. Stand-by
2. Power on / off
3. Remote control
4. Menu button
5. Volume up
6. Volume down
7. Program up
8. Program down
9. Speaker
10. Audio RCA (R)
11. Audio RCA (L)
12. Video input CINCH connector
13. S-VHS
14. Headphone
15. Antenna input
16. Audio out (R,L)
17. Scart
18. DC 12V Power supply input
19. VGA

### Please note

- See the external connections table on next page for available connections.
- Do not use Video RCA and S-Video connections at the same time, otherwise they will effect the picture each other.
- RGB inputs from scart will give you better picture quality.

## External connections table

Picture tube size/type	15" 4:3
AV1 Scart	STD.
Headphone socket	STD.
Audio/Video RCA	STD.
S. Video socket	STD.
Back audio out	STD.

STD : Standart  
OPT : Optional  
N/A : Not available

## Remote control

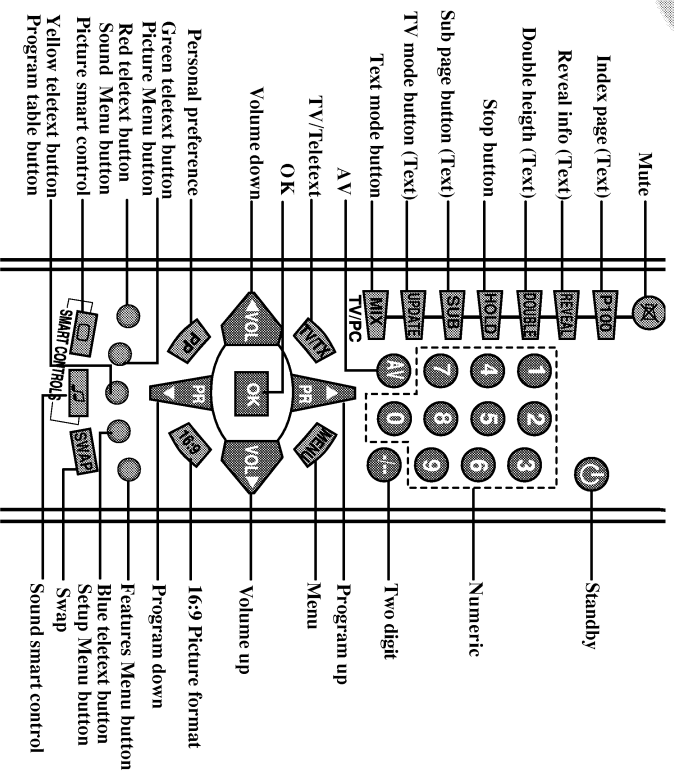

# Using the TV

## Turning on for the first time and Tuning

### TV controls

#### Stand-By mode

When your TV is working on, press the red "STAND-BY" button on the right upper corner of your remote control to switch off and the Stand-By indicator (Led) will be brighter. To turn on your TV again, press one of the numeric buttons, **Program up** or **Program down**.

**Please Note:** If you will not use your TV for a long time, do not leave it on Stand-By mode, instead switch it off from the power button on the front panel of the TV set.

#### Programme selection

Press the **Program up** or **Program down** buttons on the TV or remote control or press a **Numeric** button to select a programme.

To select a programme whose number is greater than 9 using the numeric buttons, press the +/- button first and then press the two **Numeric** buttons. For example, to select programme 12, press the +/- button followed by **1** and then **2**.

You can also select a program by pressing in the Yellow button to see the Program Table.

PROGRAM TABLE			
SKIP	MODE	NAME	DELETE
00.	05.	10.	
01.	06.	11.	
02. BBC	07.	12.	
03.	08.	13.	
04.	09.	14.	

Use the **Program up** and **Program down** buttons to scroll through the programme numbers. When you find the program number you want press the **OK** button again.

Press the **TV/TVX** button to close the Program Table.

#### Volume

Press the **Volume +** or **Volume -** button on the TV or the **Vol+** or **Vol-** button on the remote control. A sound level bar will appear on the screen.

#### Mute

To mute the sound press the **Mute** button on the remote control. A loudspeaker symbol will appear on the screen.



Press the **Mute** button again to restore the sound. The symbol will disappear.

Pressing **Volume up** buttons will also restore the sound.

But pressing the **Volume down** button will decrease the volume without restoring.

**PP** Personal preference. Press the **PP** button to revert to the default settings for the TV. (See TV setup).

**Swap**

Select the programme you would like to recall by pressing **SWAP** button. Selected programme number will appear on the lower left side of the screen. While watching any programme, you can recall the selected one by pressing **SWAP** button again. If you press swap button again you can recall the last programme you watched. You can cancel **SWAP** function by pressing **MENU** button.

**PR 01** **PR 11** **PR 12** **PR 13...** **PR 01**

**AV** Your TV has 1 scart so every time you press your AV button, your input will change as follows:

- 1 AV1 when using SCART socket 1 (RGB support).
- 2 AV2 when using RCA socket.
- 3 AVS when using the S-video socket.

Press the **AV** button again to return to TV.

## Tuning the television

There are two ways of tuning your television: Manual, where you control the tuning process or

Autoprogram where the television does it all automatically.

Your TV will sort all the channels with the AT.S. Sorting will be performed in the following order:

- a- Selected country's channels with teletext and channel names.
- b- Selected country's channels with teletext and without channel names.
- c- Selected country's channels without teletext.
- d- Foreign channels with teletext and channel names.

### Please Note

If the TV is set to a channel with no signal the TV will return to standby in 5 minutes. The last minute remaining is displayed on the screen.

### Automatic tuning (Autoprogram)

There are two ways to access the SETUP menu:

Press the blue **Setup** button.

Press the **Menu** button and use the **Program down** button to select **SETUP**. Press the **OK** button to enter the **SETUP** menu.

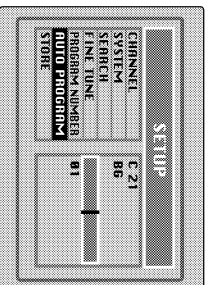
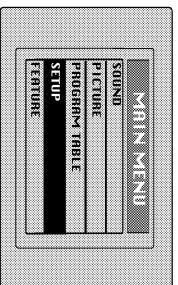

### Please note

The system will be displayed automatically on SYSTEM row i.e. BG, L, I or DK depending the receiving broadcasting system of your country. In some countries the broadcasting system can be both in BG/DK or BG/LL.

Only the TV sets produced with Pal Secam BG/DK or Pal Secam BG/LL systems can receive both BG/DK or BG/LL broadcasts. In this case the user can select the required SYSTEM using **Volume up/down** buttons.

### Please note

If you do not press any buttons for 15 seconds the TV will exit the menu system.

Use the **Program down** button to select **AUTOPROGRAM** and press the **OK** button. A list of countries will appear. Select the desired country using **Program** and **Volume** buttons.

When you are sure the aerial is connected properly press the **OK** button. Autoprogram will start.

To cancel Autoprogram whilst it is working press the **Menu** button repetitively.

As Autoprogram stores a channel it will appear briefly on the screen before the search continues.

### Your TV is now tuned and ready to use.

### Please note:

If auto sort fails to arrange the programmes in the required sequence please refer to programme organising.

## Manual tuning

If you want to tune manually:

In the Setup menu select **PROGRAM NO** using the **Program down** button and use the **Volume up** button to change the Program No to 01.

Starting with Program 01, tune in the first channel as follows:

Use the **Program down** button to select **SEARCH**.

Press the **Volume up** or **Volume down** button to start the tuning search.

When the search finds a strong channel signal it will stop searching. The picture will appear.

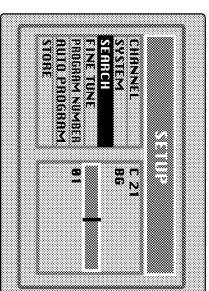

Use the **Program down** button to select **PROGRAM NO**.

Use the **Volume up/down** numeric buttons to select the desired programme number.

Use the **Program down** button to select **STORE**. Press the **OK** button and **STORED** will appear on the **STORE** line.

You have now stored the first channel.

Use the **Program up** button to select again **SEARCH** and continue the tuning procedure until you have tuned in all the programmes you want or the television can receive.

## Tuning with channel numbers

Enter the **SETUP** menu by pressing the blue button.

Press **OK** button when CHANNEL row is blue.

Use **OK** button to select "S" for cable channels and "C" for terrestrial broadcast.

Enter the channel number using the Numeric buttons or use the **Volume up/down** buttons to tune channels.

Use the **Program down** button to select **PROGRAM NUMBER**.

Use the **Volume up/down** or numeric buttons to select the desired programme number.

Use the **Program down** button to select **STORE**. Press the **OK** button and **STORED** will appear on the **STORE** line.

You have now stored the first channel.

Use the **Program up** button to select again **CHANNEL**, and continue the tuning procedure until you have tuned in all the programmes you want or the television can receive.

To exit the **SETUP** menu press the **TV/TX** button.

## Fine tuning

Although the search and Autoprogram will automatically try and tune to the best reception, in areas of poor reception a bit of fine tuning may be required.

In the **SETUP** menu use the **Program up/down** buttons to select **FINE TUNING**. Use the **Volume up** and **Volume down** buttons to fine tune.

When you have finished use the **Program down** button to select **STORE** and press the **OK** button.

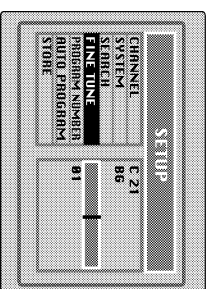

## Program organising

Once you have tuned in all the channels you want, you can change their programme number; if required, and name them.

To enter the **PROGRAM TABLE** menu press the **Menu** button and select **PROGRAM TABLE** and press the **OK** button or press directly the **Yellow** button.

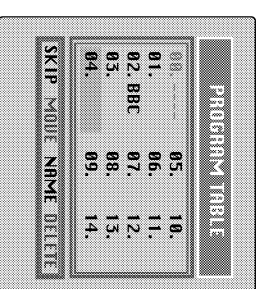

The buttons used to edit the programs are shown at the bottom of the display:

Button	Name
Blue button	-
Green button	-
Pink button	-
Red button	-

### To name the programmes

You can name the programmes and AV inputs.

Press the **Blue** button, the selected programme will be highlighted.

Use the **Program up** and **Program down** buttons to select the letters and numbers and the **Volume up** and **Volume down** buttons to move through the name.

Press the **Blue** button again to store the name.

Repeat this process to name all the programmes.

### Please Note

1. Some TV channels may send their names with teletext transmission. In this case their names will be automatically shown on the name line.

1. Child locked programmes will be shown as "●".

### To move the programmes

You can move the programmes around the programme list to the order you want

Select the programme you want to move and press the **Green** button. The programme will turn to yellow. Select the number you want to move and press the **Green** button again and the programme will be moved to that number.

All the following programmes are shifted down by one place.

### To delete a programme

To delete a programme, select it and press the **Pink** button.

The programme will be deleted.

All the following programmes are shifted up by one position.

### To skip programmes

Skipped programmes will not appear when you move through the program list using the **Program up/Program down** buttons. They can still be selected using the numeric buttons or the **OK** button.

Select the programs you want to skip and press the **Red** button. The program will turn red. To unskip the program press the **Red** button again.

To exit the **PROGRAM EDIT** press the **TV/TX** button once or the **Menu** button twice.

When you select a programme, the information you entered in the **PROGRAM EDIT** menu will appear on the top of the screen i.e. P1 BBC1. This will disappear after about three seconds.

## TV set up

The TV set up is accessed through a menu system.

Once you have stored your set up, this is the set up the TV will default to when you switch it on.

To enter the MAIN menu press the **Menu** button.

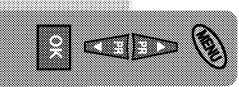

Red button - **SOUND**  
Green button - **PICTURE**  
Pink button - **FEATURES**

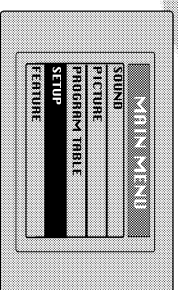

### Please note

If you do not press any buttons for 15 seconds the TV will exit the menu system.

## Sound menu (red button)

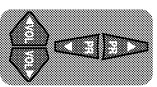
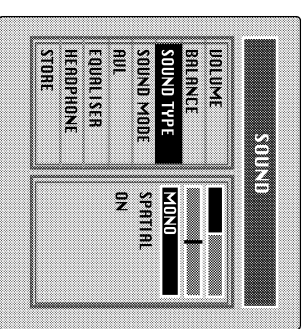

Select the required item in the menu using the **Program up/down** buttons and make the changes pressing **Volume up/down** buttons. Use the **OK** button to enter **HEADPHONE** from main menu.

## Volume

Set default volume using the **Volume up** and **down** buttons.

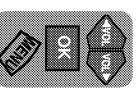

To save your settings, select **STORE** and press the **OK** button. **STORED** will be displayed. Press the **Menu** button to go back to the previous menu.

## Balance

Sets the sound balance mode using the **Volume up** and **down** buttons

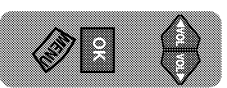

To save your settings, select **STORE** and press the **OK** button. **STORED** will be displayed. Press the **Menu** button to go back to the previous menu.

## Sound type

This item shows **STEREO** when receiving stereo transmission and **MONO** for mono transmissions.

The TV can be produced to receive the **NICAM** broadcasts as a optional feature.

If the channel you are watching is in **Nicam** stereo the **On Screen Display** will show **NICAM STEREO** for a while.

### Please Note

If, while watching a **nicam** stereo channel, the signal strength drops and the system cannot receive **nicam** stereo the **OSD** will show **MONO**. If the signal strength increases again and **nicam** stereo can be received again, the **OSD** will show **NICAM STEREO**.

## Dual V/I

Some broadcasters supply the programmes in two languages. To able to listen the second language select **DUAL II** by **SOUND TYPE** using **Volume up/down** buttons.

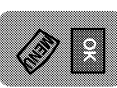

To save your settings, select **STORE** and press the **OK** button. **STORED** will be displayed. Press the **Menu** button to go back to the previous menu.

## Sound mode

You can select **NORMAL** or **SPATIAL Volume up/down** buttons.

**SPATIAL** sound is an 'expanded stereo'. It gives the impression that the two speakers in the TV are further apart than they really are.

## AVL

TV transmitters have different sound levels. **AVL** (automatic volume limiting) maintains the same sound level as you switch from program to program.

To apply this press **Volume up** or **down** button and select **ON** for **AVL** in **Sound Features** menu.

## Equalizer

To access the 5 band equalizer menu press **Volume up** or **down** button and press **OK** on the **Equalizer** line.

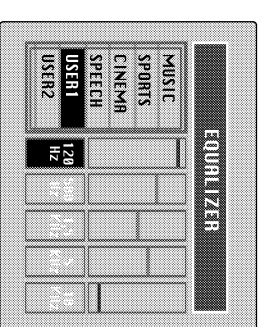

In this menu there are a series of preset equalizer settings for different types of sound output.

There are four music settings - **MUSIC**, **SPORTS**, **CINEMA**, **SPEECH** and **USER1** & **USER2** modes.

**MUSIC**, **SPORTS**, **CINEMA**, **SPEECH** are factory presets.

**USER** modes allow you to set your own sound outputs as follows:

Press the **OK** button to enter the **EQUALIZER** menu.

Use the **Program down** button to select **USER1**.

Press **OK** button to adjust the frequency band levels.

Use the **Volume up** button to select the **KHz** column you want to change.

Use the **Program up/down** buttons to make the changes.

To save your settings, press the **OK** button. Press the **Menu** button to go back to the previous menu.

You can also adjust the settings of **USER2** by the same method.

You can change the equalizer setting whilst watching the TV using the sound **Smart** control.

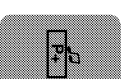

Press the sound **Smart control** to page through the different equalizer settings and select the one you want.

Once you have switched the TV off the equalizer setting will revert to the stored setting.

## Headphone

You can set up the volume, balance, bass treble and sound type (stereo or mono) of the headphone output.

Use **OK** button to enter the **HEADPHONE** menu.

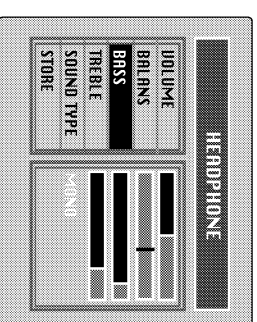

To save your settings, select **STORE** and press the **OK** button. **STORED** will be displayed. Press the **Menu** button to go back to the previous menu.

## Picture menu (Green button)

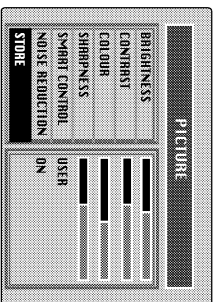

The picture menu allows you to set up the following:  
**BRIGHTNESS**  
**CONTRAST**  
**COLOUR**  
**SHARPNESS**  
**SMART CONTROL**  
**and NOISE REDUCTION**

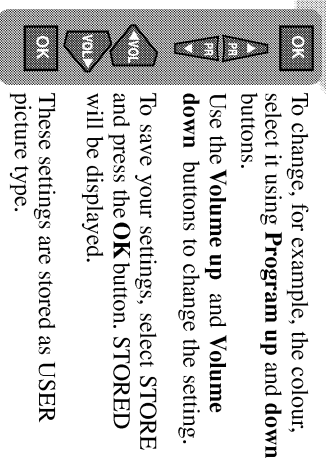

To change, for example, the colour, select it using **Program up** and **down** buttons.  
 Use the **Volume up** and **Volume down** buttons to change the setting.  
 To save your settings, select **STORE** and press the **OK** button. **STORED** will be displayed.  
 These settings are stored as **USER** picture type.

You can change the picture type whilst watching the TV using the picture **Smart** control.  
 Press the picture **Smart control** page through the different picture types and select the one you want: **SOFT**, **NATURAL**, **RICH** or **USER**.

**NOISE REDUCTION:** You can reduce the noise effects in the pictures by selecting **ON**.

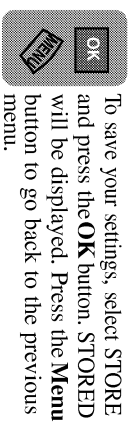

To save your settings, select **STORE** and press the **OK** button. **STORED** will be displayed. Press the **Menu** button to go back to the previous menu.

## Features Menu (Purple button)

To select **Features** menu press the menu button and using the **Program up** and **down** buttons select **Features**.

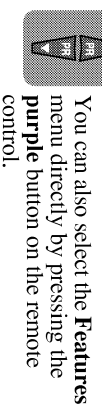

You can also select the **Features** menu directly by pressing the **purple** button on the remote control.

The **Features** menu allows you to set up the following:  
**CHILD LOCK**  
**CLOCK**  
**TIMER**  
**BACKGROUND**  
**LANGUAGE**

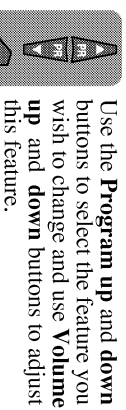

Use the **Program up** and **down** buttons to select the feature you wish to change and use **Volume up** and **down** buttons to adjust this feature.

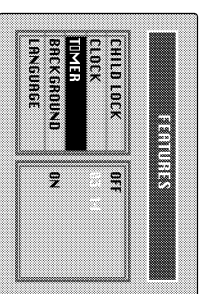

**Child Lock:** Using the **Child Lock**, you can lock any Program you want so that adult channels can not be watched by children.

You can cancel child lock any time you want. To cancel **Child Lock**, select **Child Lock** as **OFF** when you are watching that program.

**Clock:** Use the numeric buttons to set the real time.

**Note:** If you enter any channel with teletext transmission, clock will automatically set to real time.

**Background:** You can adjust the menu background as **ON** or **OFF**.

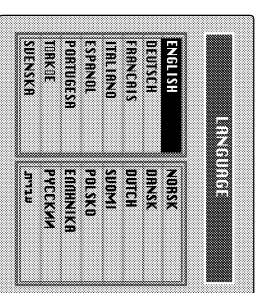

**Language:** You can select one of the 16 languages by pressing **OK** button in the language selection.

**Timer:** Use **Program up** and **down** buttons to select **Timer** in the features menu. Using the **Timer** function, you can switch to a specific programme at a pre-programmed time or you can turn your TV off at the time you want your TV to be turned off.

Press **OK** to access the **Timer** menu.

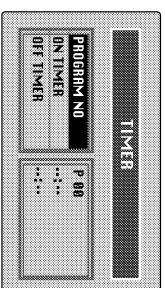

**On Timer:** Use the numeric buttons to set the time that you want your TV to be turned on (TV should be on stand-by mode).

**Off Timer:** Use the numeric buttons to set the time that you want your TV to be turned off (Stand-by mode).

**Program No:** Use the numeric buttons to set the programme number that will be shown when you set the **On Time**.

# Using Teletext

Teletext is an information system that displays text on your TV screen. Using the teletext control buttons you can view pages of information that are listed in the teletext index.

## Please Note

No on screen display is available in text mode. The contrast, brightness and colour cannot be changed but the volume control is still available.

## To enter Text mode

### Please Note

Make sure the TV channel you are watching transmits teletext. If not NO TEXT sign will be shown on the screen.

Press the **TV/TEXT** button. The text page will appear, normally the index page.

## To exit Text mode

Press the **TV/TEXT** button. The TV will return to the channel you were watching.

## To select a page of text

Find the number of the page in the index and enter it using the **Numeric** buttons. The number of the page will appear in the top left hand corner of the screen.

The page counter will search for your page. When it finds it, the page will be displayed.

To move to the next page of text press the **Program up** button.

To move to the previous page press the **Program down** button.

To return to the index page press the **P100** button.

## TV/text mix

To view a page of text whilst watching a TV programme press the **MIX** button. The text will be superimposed over the TV programme.

Press the **MIX** button again to return to the text page.

## Page search whilst watching TV

In Text mode press the **Update** button. The TV will return to TV mode with the text page number in the top left hand corner of the screen.

Enter the page number you want using the **Numeric** buttons.

The top line of the text page will appear whilst the text searches for your page. When the page is found the number will remain in the top left hand corner of the screen.

Press the **Update** button to view your selected page of text.

## Double height text

If you have difficulty reading the text on the TV you can double the height of the text.

Press the **Double height** button. The top half of the page will be displayed in double height text.

Press the **Double height** button again. The bottom half of the page will be displayed in double height text.

Press the **Double height** button again to return to the full page.

## Page Stop

If the page of text you have selected contains sub pages, these sub pages will automatically be displayed in order with a delay to allow you to read the page.

To stop the move to the next sub page press the **STOP** button. **STOP** will appear in the top left hand corner.

To continue moving through the sub pages press the **STOP** button again.

## To select a sub page

If the page of text you are viewing contains sub pages, the number of the sub page you are on and the total number of sub pages is displayed on the right of the screen i.e. 1/7.

To select a sub page press the **SUB** button. Press green button to select next sub-page or press red button to select previous sub-page.

Enter the number of the sub page, using the **Numeric** buttons in the format S0001 for sub page 1.

The teletext will search for the sub page. This may take some time. To return to the TV whilst the teletext is searching press the **Update** button.

When the page number is found it will appear in the top left hand corner of the screen.

Press the **Update** button again to view the text page.

## To reveal information

Press the **Rev** button to reveal concealed information (quiz answers etc.).

Press the **Rev** button again to conceal the information again.

## Clock

Press the **Sub** button, whilst watching a TV program, to display the time.

## Fast text

At the bottom of the teletext screen is a row of subject headings in red, green yellow and blue.

The remote control has a row of coloured buttons corresponding to the row of coloured subjects on the screen.

Pressing one of the coloured buttons will take you directly to the page corresponding to the subject heading.

# Connecting external equipment

You can connect a wide range of audio and video equipment to your TV.

## Connecting a video recorder

**1 Via SCART**  
Make sure the TV and video recorder are both switched off.

Plug one end of the SCART lead (not supplied) into the back of the video recorder and the other end into one of the SCART sockets on the back of the TV.

Switch on the video recorder and the TV.

**AV**  
Press the AV button on the remote control to select AV1 to correspond with the SCART socket you are using on the back of the TV.

### Please note:

You can connect a RGB external equipment via Scart. It is necessary to you use full Scart cable for this purpose.

Select the video outputs of external device by using its menu to RGB if it's available.

**2 Via RCA lead (optional)**  
Make sure the TV and video recorder are both switched off.

Plug one end of the RCA lead into the video and audio out sockets on the back of the video recorder and plug the other end into the video and audio in sockets of the TV.

If the sound is in mono use the Audio Input L. In the SOUND menu select MONO.

**3 Via aerial socket**  
Make sure the TV and video recorder are both switched off.

Unplug the aerial lead from the TV and plug it into the aerial socket on the video recorder (if fitted).

Plug a coaxial plug into the RF out socket on the rear of the video recorder and plug the other end into the aerial socket of the TV.

Switch on the video recorder and the TV.

If your video recorder has a test signal, switch it on. (Refer to the video recorder user guide).

See 'Tuning the TV' and carry out the tuning procedure for the video recorder test signal. Select a programme number 0.

**4 Via RCA lead and S-Video socket**  
You can also connect it through the S-Video socket of the TV.

Plug the S-Video plug into the S-Video socket and the audio leads into the audio sockets.

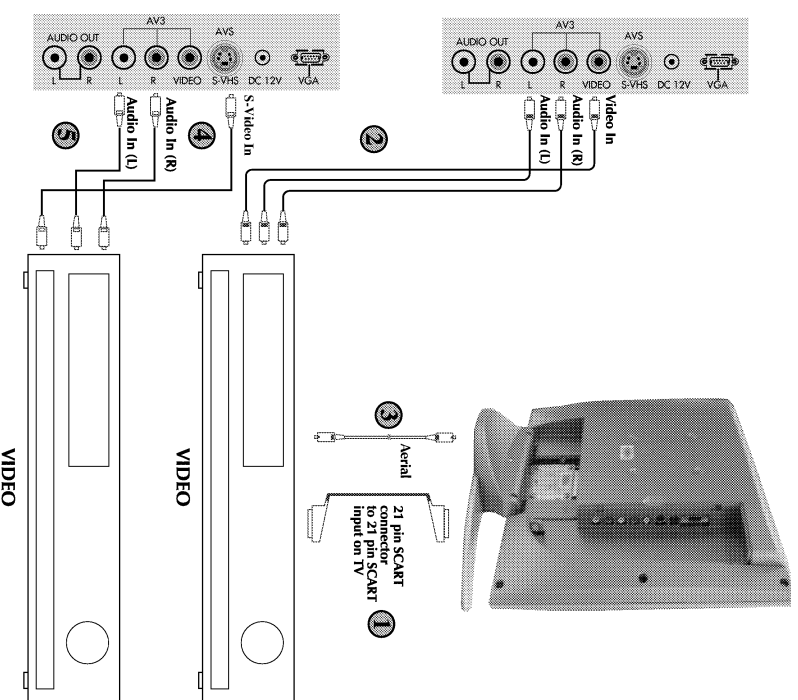

## Connecting a DVD player

**1 Via SCART**  
Make sure the TV and DVD player are both switched off.

Plug one end of the SCART lead (not supplied) into the back of the DVD player and the other end into the SCART socket on the back of the TV.

Switch on the DVD and the TV.

**2 Via RCA lead**  
Make sure the TV and DVD player are both switched off.

Plug one end of the RCA lead into the video and audio out sockets on the back of the DVD player and plug the other end into the video and audio in sockets of the TV.

**3 Via RCA lead and S-Video socket**  
You can also connect it through the S-Video socket of the TV.

Plug the S-Video plug into the S-Video socket and the audio leads into the audio sockets.

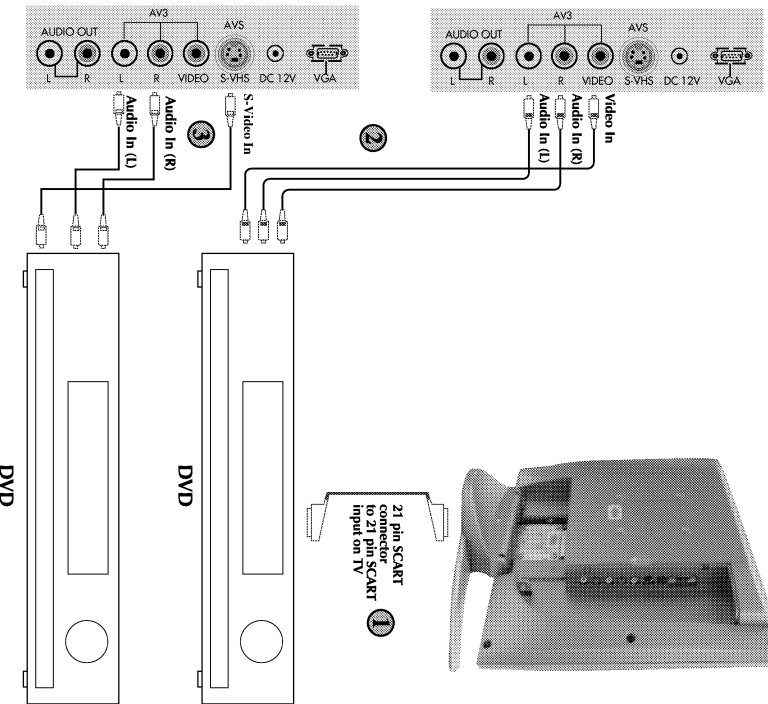

## Connecting a decoder

**Via SCART**  
Make sure the TV and decoder are both switched off.

Plug one end of the SCART lead (not supplied) into the back of the decoder and the other end into the SCART on the back of the TV.

Switch on the decoder and the TV.

Press the **AV** button on the remote control to select AV1.

**2 Via RCA lead**  
Make sure the TV and decoder are both switched off.

**Note:** For Decoder connection Via RCA lead your Decoder device should have the tuner built in.

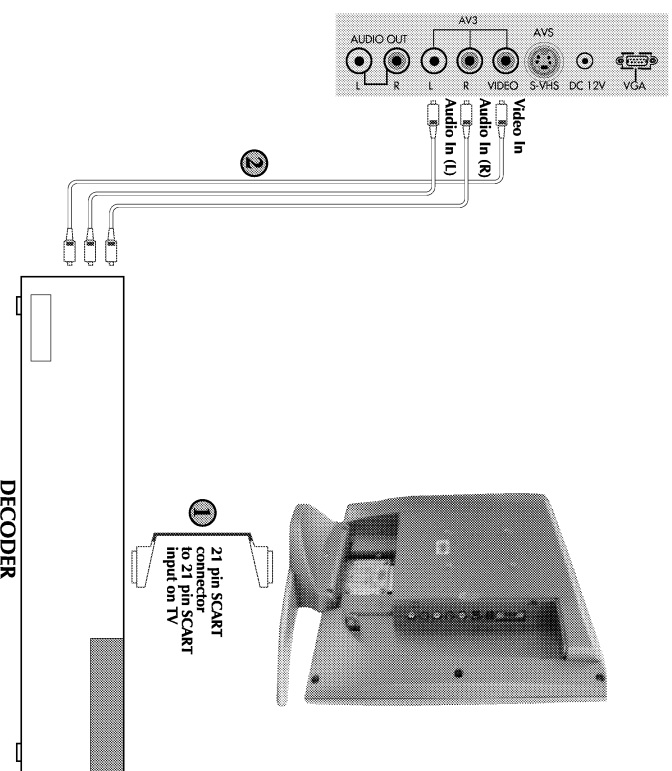

Plug one end of the RCA lead into the video and audio out sockets on the back of the decoder and plug the other end into the video and audio in sockets on the TV.

## INTRODUCTION

Because your 15"LCD-TV equipment is provided with VGA inputs, it may be used as a PC monitor as well. (Pug&Play)

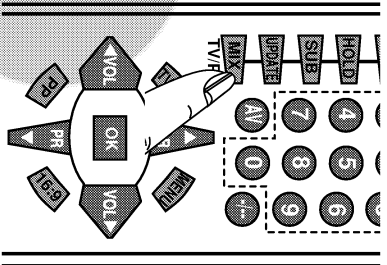

### Entering the PC Mode

To enter the LCD-TV in to the monitor (PC) mode, the "MIX(TV/PC)" button on your remote control is used. Each time the "MIX(TV/PC)" button is pressed, operation changes from the PC mode, press the "MIX" button again. In addition, you may return to the TV mode by selecting the "TV SELECTION" option from the monitor menu alternatively.

**Note 1:** When the system is in the monitor mode, the sound from the TV channel selected may be heard from the speakers. When you enter this mode, the sound control buttons on the remote control. ("VOL"/"VOL" MUTE) become functional.  
**Note 2:** When the system is in the monitor mode, the STANDBY button is operational. Upon exit from STANDBY, the system starts up in the TV mode again.

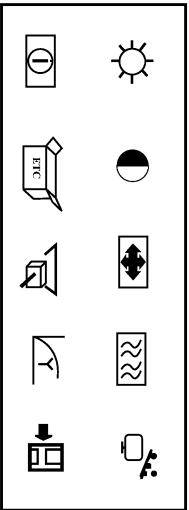

### PC Mode Menu Structure

After changing to the PC mode, you may access the monitor menus by pressing the "MENU" button on the front panel of the system

To browse in the menus, you may use the "PR"/"PR" buttons and Vol+ or Vol- buttons to select the type of adjustment you wish to make. Once you make your selection, you may set the desired adjustment value using the "PR"/"PR" buttons.

### BRIGHTNESS

After entering the Brightness Menu using the "VOL"/"VOL" buttons, you may set the brightness value of the monitor to the desired level by using the "PR"/"PR" buttons.

### CONTRAST

After entering the Contrast Menu using the "VOL"/"VOL" buttons, you may set the contrast value of the monitor to the desired level by using the "PR"/"PR" buttons.

### POSITION

After entering the Position Menu using the "VOL"/"VOL" buttons, you may set the geometrical adjustment value of the monitor to the desired level by using the "PR"/"PR" buttons.

H-POSITION : Horizontal position adjustment  
 V-POSITION : Vertical position adjustment

### IMAGE

After entering the Image Menu using the "VOL"/"VOL" buttons, you may set the phase adjustment value of the monitor to the desired level by using the "PR"/"PR" buttons.  
 PHASE : ADC sampling phase adjustment  
 CLOCK : ADC clock count Per line

**AUTO CONFIG :** Allows the entry of optimum geometrical adjustments based on the input mode  
**INFORMATION :** Displays the input mode information on the screen.

### MISCELLANEOUS

You may enter the factory default settings, Menu position and duration on the screen, resolution settings etc. by selecting the MISCELLANEOUS option.  
**FACTORY RESET :** Loads the factory default settings  
**OSD TIMEOUT :** The on-screen timeout may be adjusted to a value between 5 - 60 seconds.  
**OSD POSITION :** Used for adjusting the OSD Horizontal and Vertical position  
**NATIVE MODE :** Displays the input cursor in its actual resolution

**TV SELECTION :** To change from Monitor mode to TV mode

**GAMMA :** Correction of linear RGB data to compensate for non-linear response of TFT display.

**MOIRE :** Correction of distortions giving an image of the picture lines superimposed over one another.

**SAVE :** Stores the settings entered.

**NOTE:** The user can store the geometrical adjustments (H-Position, V-Position) entered for 6 different input graphic modes. When the Autoconfig is performed, the settings provided for that mode are stored, therefore, activating the Autoconfig function each time the mode is changed, is not necessary. When the user stores the settings for a 7th mode, the first mode stored will be erased

### Warning Messages

**1. No SYNC:** The VGA input code (resolution) is missing. The "NO SYNC" message appears on the display. The message stays on the screen for 30 seconds and if no other VGA input signal that is supported by the system is not provided within that period, the system will go to "POWER SAVING" mode in order to protect the LCD panel. In this mode, the display will turn off, but the sound from the selected tuner channel will be audible

**2. Input Not Supported:** The input code (resolution) is not a supported graphics mode. The message "INPUT NOT SUPPORTED" appears on the display. The message stays on the screen until a supported graphic input code is received.

### Input Graphic Modes Supported (progressive non-interlaced)

640 x 400 x 56 Hz	640 x 480 x 85 Hz	800 x 600 x 85 Hz
640 x 480 x 60 Hz	720 x 400 x 70 Hz	832 x 624 x 75 Hz
640 x 480 x 69 Hz	720 x 400 x 85 Hz	1024 x 768 x 60 Hz
640 x 480 x 72 Hz	800 x 600 x 56 Hz	1024 x 768 x 70 Hz
640 x 480 x 75 Hz	800 x 600 x 60 Hz	1024 x 768 x 75 Hz
640 x 350 x 72 Hz	800 x 600 x 72 Hz	1024 x 768 x 85 Hz
640 x 480 x 66 Hz (MAC)	800 x 600 x 75 Hz	

### Important Warning:

1. When the system changes from TV mode to VGA mode for the first time, the sound from the speakers is muted, but available through the ear-phones
2. When a particular VGA mode is displayed for the first time, selecting the "Autoconfiguration" option may be necessary. The position adjustment as well as the H-Position and V-Position fine adjustments must be entered and the values "saved (stored)"
3. When the signal is cut off, depending on the VGA power-saving standard, the message "NO SIGNAL" is displayed on the screen for 30 seconds. At the end of this period, the system turns off, providing an energy saving of 30 watts.



## Connecting TV with video and satellite/digital receiver

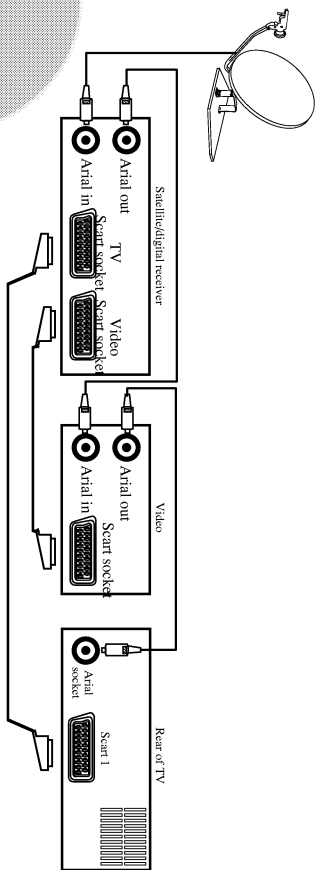

## Connecting TV with camcorder

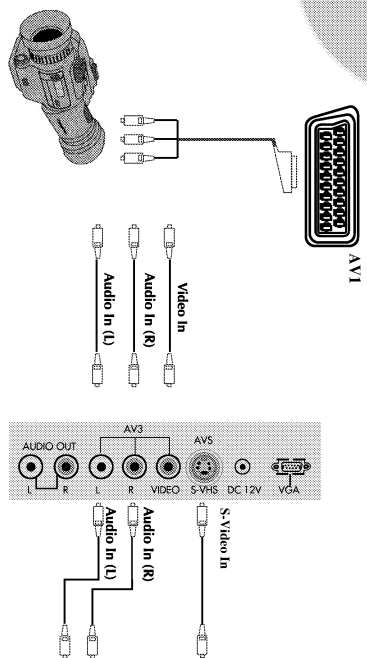

## Connecting TV games and computer

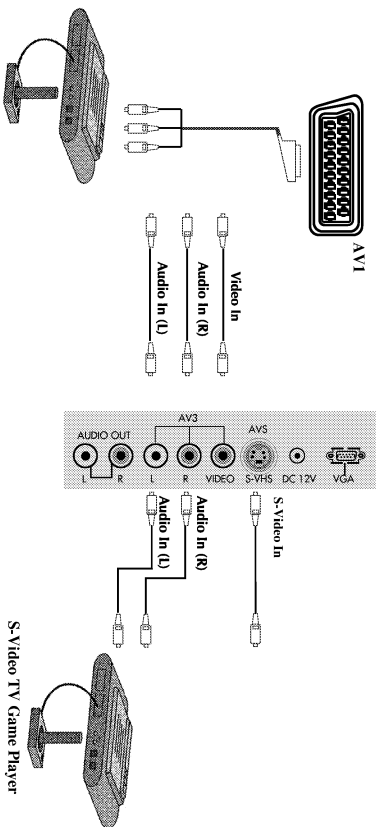

# INTERCONNECTION GUIDE

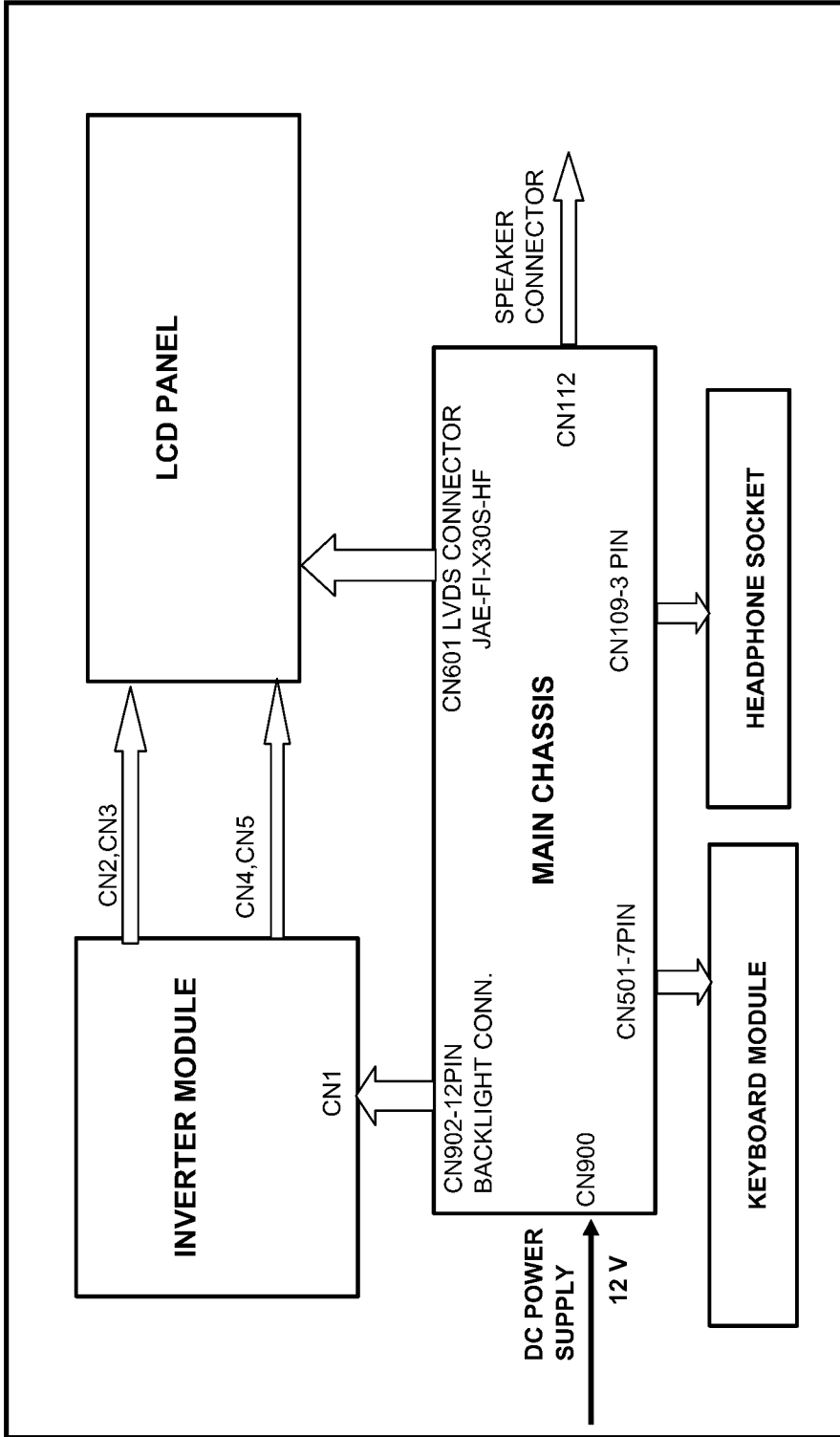

# BLOCK DIAGRAM

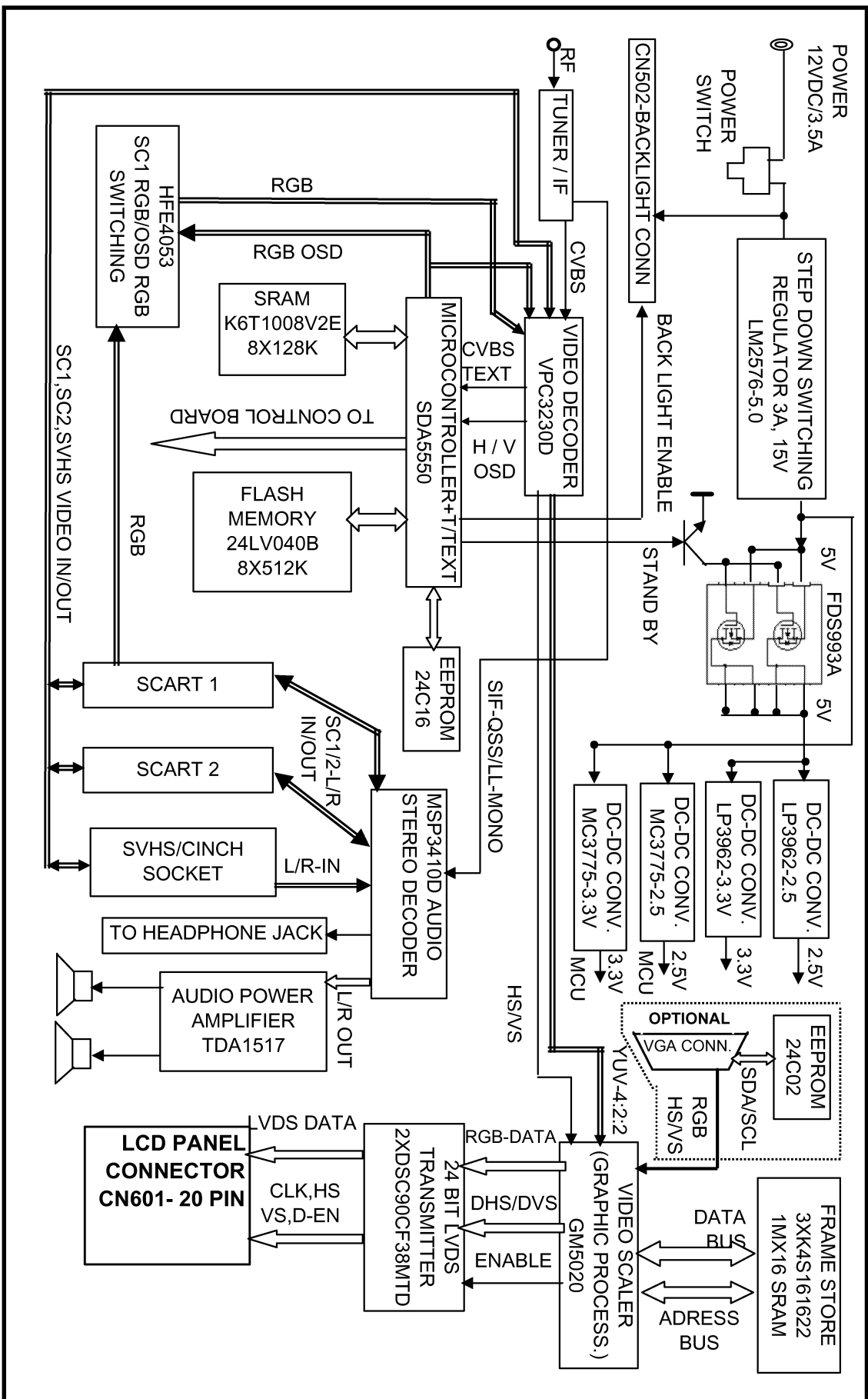

# SDA5550 MICROCONTROLLER

## Features

### General

- Feature selection via special function register
- Simultaneous reception of TTX, VPS, PDC, and WSS (line 23)
- Supply Voltage 2.5 and 3.3 V
- ROM version package P-SDIP 52, P-MQFP64
- Romless version package P-MQFP100,P-LCC84

### External Crystal and Programmable clock speed

- Single external 6MHz crystal, all necessary clocks are generated internally
- CPU clock speed selectable via special function registers.
- Normal Mode 33.33 Mhz CPU clock, Power Save mode 8.33 Mhz

### Microcontroller Features

- 8bit 8051 instruction set compatible CPU.
- 33.33-MHz internal clock (max.)
- 0.360  $\mu$ s (min.) instruction cycle
- Two 16-bit timers
- Watchdog timer
- Capture compare timer for infrared remote control decoding
- Pulse width modulation unit (2 channels 14 bit, 6 channels 8 bit)
- ADC (4 channels, 8 bit)
- UART

## BLOCK DIAGRAM

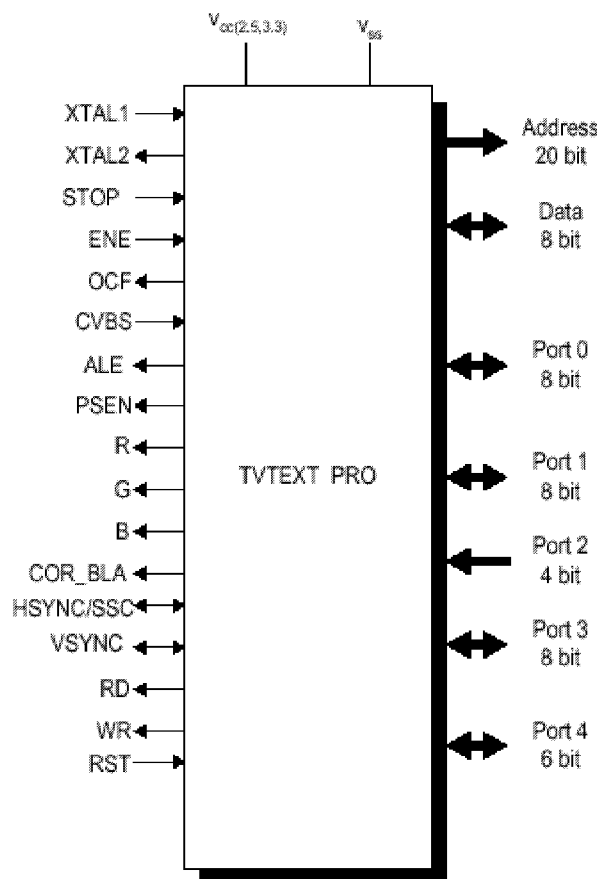

Pin Configuration P-LCC-84 (ROMless Version)  
(top view)

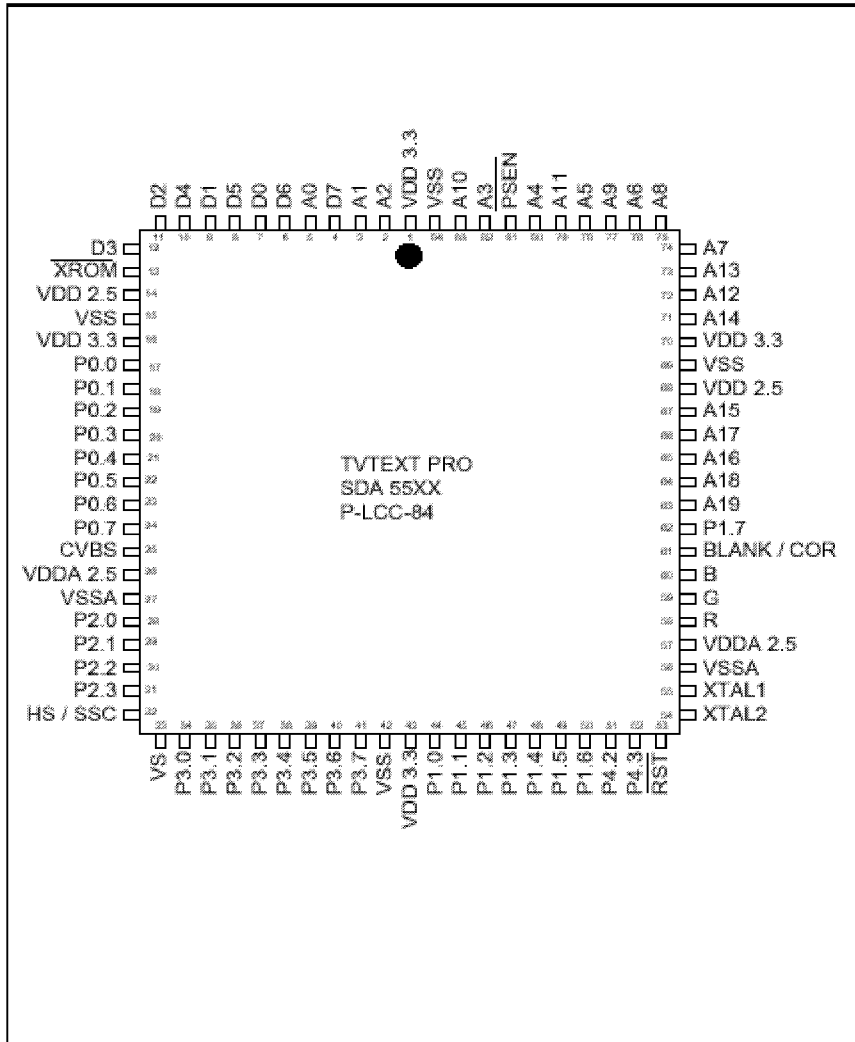

# Video Processing - VPC3230D

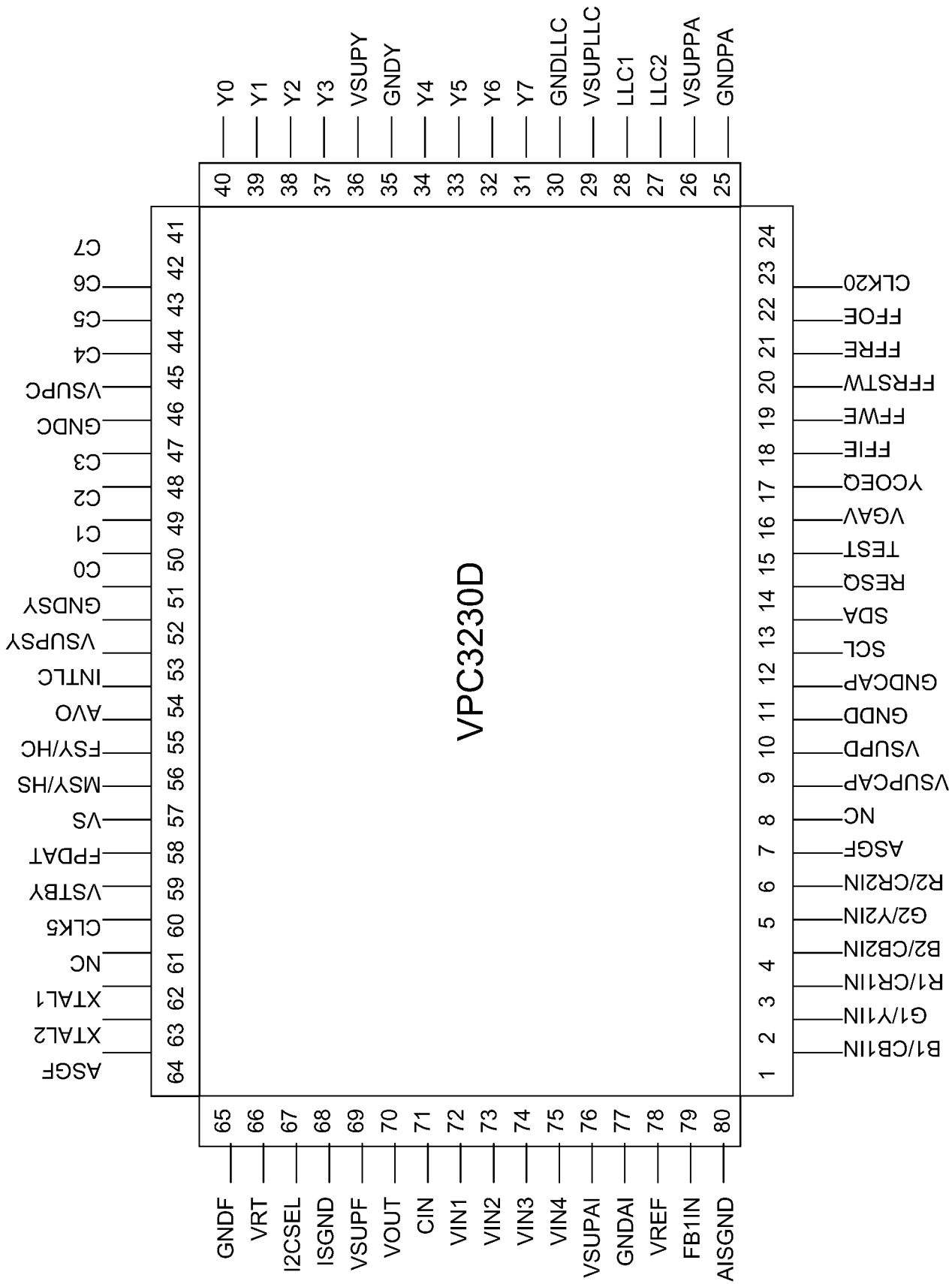

## 1. Features

### Video Decoding

- 4 Composite inputs, 1 S-VHS input
- Composite video & sync output
- integrated high-quality A/D converters
- Adaptive 2H comb filter Y/C separator
- 1H NTSC comb filter
- Multi-standard color decoder(1 Crystal)
- Multi-standard sync decoder
- Black line detector

### Video Decoding

- Horizontal scaling(0.25 to 4)
- Panorama vision
- Black level expander
- Dynamic peaking
- Soft limiter(gamma correction)
- Color transient improvement

### RGB Processing

- Programmable RGB matrix
- Digital color bus interface
- Additional analog RGB/Fast blank input
- Half contrast switch
- Picture frame generator

### Deflection

- Scan velocity modulation output
- High performance H/V deflection
- Separate ADC for tube measurements
- EHT compensation

### Miscellaneous

- One 20.25MHz crystal, few external components
- Embedded RISC controller(80 MIPS)
- I<sup>2</sup>C Bus interface
- Single 5V power supply
- Submicrom COMS technology
- 64 pin PSDIP package

# Block Diagram

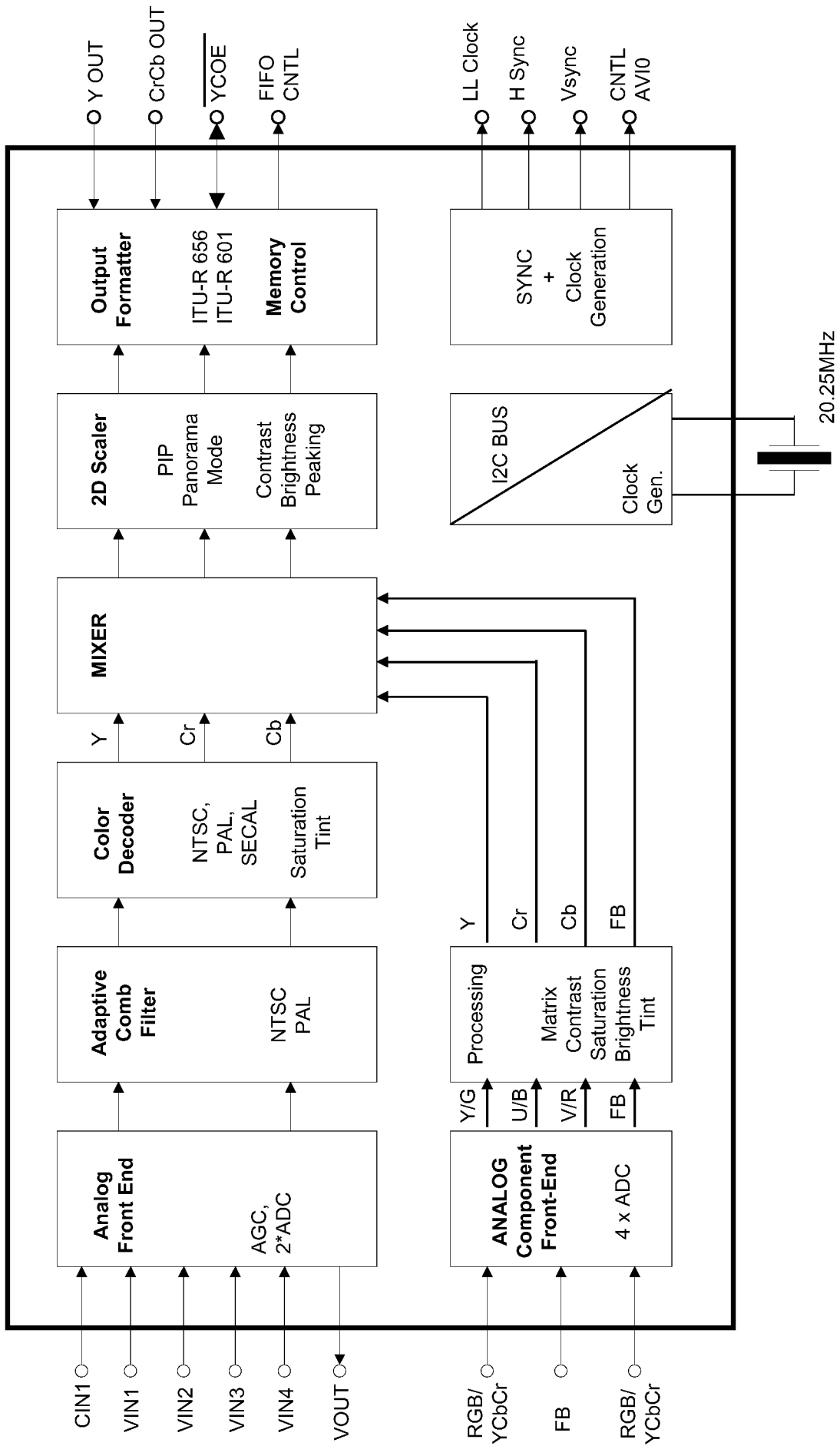



## Video Processing - VPC3230D

Pin No.	Pin Name	Type	Short Description
1	B1/CB1IN	IN	Blue1/Cb1 Analog Component Input
2	G1/Y1IN	IN	Green1/Y1 Analog Component Input
3	R1/CR1IN	IN	Red1/Cr1 Analog Component Input
4	B2/CB2IN	IN	Blue2/Cb2 Analog Component Input
5	G2/Y2IN	IN	Green2/Y2 Analog Component Input
6	R2/CR2IN	IN	Red2/Cr2 Analog Component Input
7	ASGF		Analog Shield GND F
8	NC	-	No connected
9	V SUPCA	SUPPLYD	Supply Voltage, Digital Decoupling Circuitry
10	V SUPD	SUPPLYD	Supply Voltage, Digital Circuitry
11	GND D	SUPPLYD	Ground, Digital Circuitry
12	GND CAP	SUPPLYD	Ground, Digital Decoupling Circuitry
13	SCL	IN/OUT	I 2 C Bus Clock
14	SDA	IN/OUT	I 2 C Bus Data
15	RESQ	IN	Reset Input, Active Low
16	TEST	IN	Test Pin, connect to GND D
17	VGAV	IN	VGAV Input
18	YCOEQ	IN	Y/C Output Enable Input, Active Low
19	FFIE	OUT	FIFO Input Enable
20	FFWE	OUT	FIFO Write Enable
21	FFRSTW	OUT	FIFO Reset Write/Read
22	FFRE	OUT	FIFO Read Enable
23	FFOE	OUT	FIFO Output Enable
24	CLK20	IN/OUT	Main Clock Output 20.25 MHz

Pin No.	Pin Name	Type	Short Description
25	GND PA	SUPPLYD	Ground, Pad Decoupling Circuitry
26	V SUPPA	SUPPLYD	Supply Voltage, Pad Decoupling Circuitry
27	LLC2	OUT	Double Clock Output
28	LLC1	IN/OUT	Clock Output
29	V SUPLLC	SUPPLYD	Supply Voltage, LLC Circuitry
30	GND LLC	SUPPLYD	Ground, LLC Circuitry
31	Y7	OUT	Picture Bus Luma (MSB)
32	Y6	OUT	Picture Bus Luma
33	Y5	OUT	Picture Bus Luma
34	Y4	OUT	Picture Bus Luma
35	GND Y	SUPPLYD	Ground, Luma Output Circuitry
36	V SUPY	SUPPLYD	Supply Voltage, Luma Output Circuitry
37	Y3	OUT	Y Picture Bus Luma
38	Y2	OUT	Y Picture Bus Luma
39	Y1	OUT	Y Picture Bus Luma
40	Y0	OUT	Y Picture Bus Luma(LSB)
41	C7	OUT	Picture Bus Chroma (MSB)
42	C6	OUT	Picture Bus Chroma
43	C5	OUT	Picture Bus Chroma
44	C4	OUT	Picture Bus Chroma
45	V SUPC	SUPPLYD	Supply Voltage, Chroma Output Circuitry
46	GND C	SUPPLYD	Ground, Chroma Output Circuitry
47	C3	OUT	Picture Bus Chroma
48	C2	OUT	Picture Bus Chroma

## Video Processing - VPC3230D

Pin No.	Pin Name	Type	Short Description
49	C1	OUT	Picture Bus Chroma
50	C0	OUT	Picture Bus Chroma(LSB)
51	GND SY	SUPPLYD	Ground, Sync Pad Circuitry
52	V SUPSY	SUPPLYD	Supply Voltage, Sync Pad Circuitry
53	INTLC	OUT	Interlace Output
54	AVO	OUT	Active Video Output
55	FSY/HC	OUT	Front Sync/ Horizontal Clamp Pulse
56	MSY/HS	IN/OUT	Main Sync/Horizontal Sync Pulse
57	VS	OUT	Vertical Sync Pulse
58	FPDAT	IN/OUT	Front-End/ Back-End Data
59	V STBY	SUPPLYA	Standby Supply Voltage
60	CLK5	OUT	CCU 5 MHz Clock Output
61	NC	-	No connected
62	XTAL1	IN	Analog Crystal Input
63	XTAL2	OUT	Analog Crystal Output
64	ASGF		Analog Shield GND F
65	GND F	SUPPLYA	Ground, Analog Front-End
66	VRT	OUT	Reference Voltage Top, Analog
67	I2CSEL	IN	I 2 C Bus Address Select
68	ISGND	SUPPLYA	Signal Ground for Analog Input, connect to GND F
69	V SUPF	SUPPLYA	Supply Voltage, Analog Front-End
70	VOUT	OUT	Analog Video Output

Pin No.	Pin Name	Type	Short Description
71	CIN	IN	Chroma / Analog Video 5 Input
72	VIN1	IN	Video 1 Analog Input
73	VIN2	IN	Video 2 Analog Input
74	VIN3	IN	Video 3 Analog Input
75	VIN4	IN	Video 4 Analog Input
76	V SUPAI	SUPPLYA	Supply Voltage, Analog Component Inputs Front-End
77	GND AI	SUPPLYA	Ground, Analog Component Inputs Front-End
78	VREF	OUT	Reference Voltage Top, Analog Component Inputs Front-End
79	FB1IN	IN	Fast Blank Input
80	AISGND	SUPPLYA	Signal Ground for Analog Component Inputs, connect to GND AI

# Audio Processing - MSP3440G

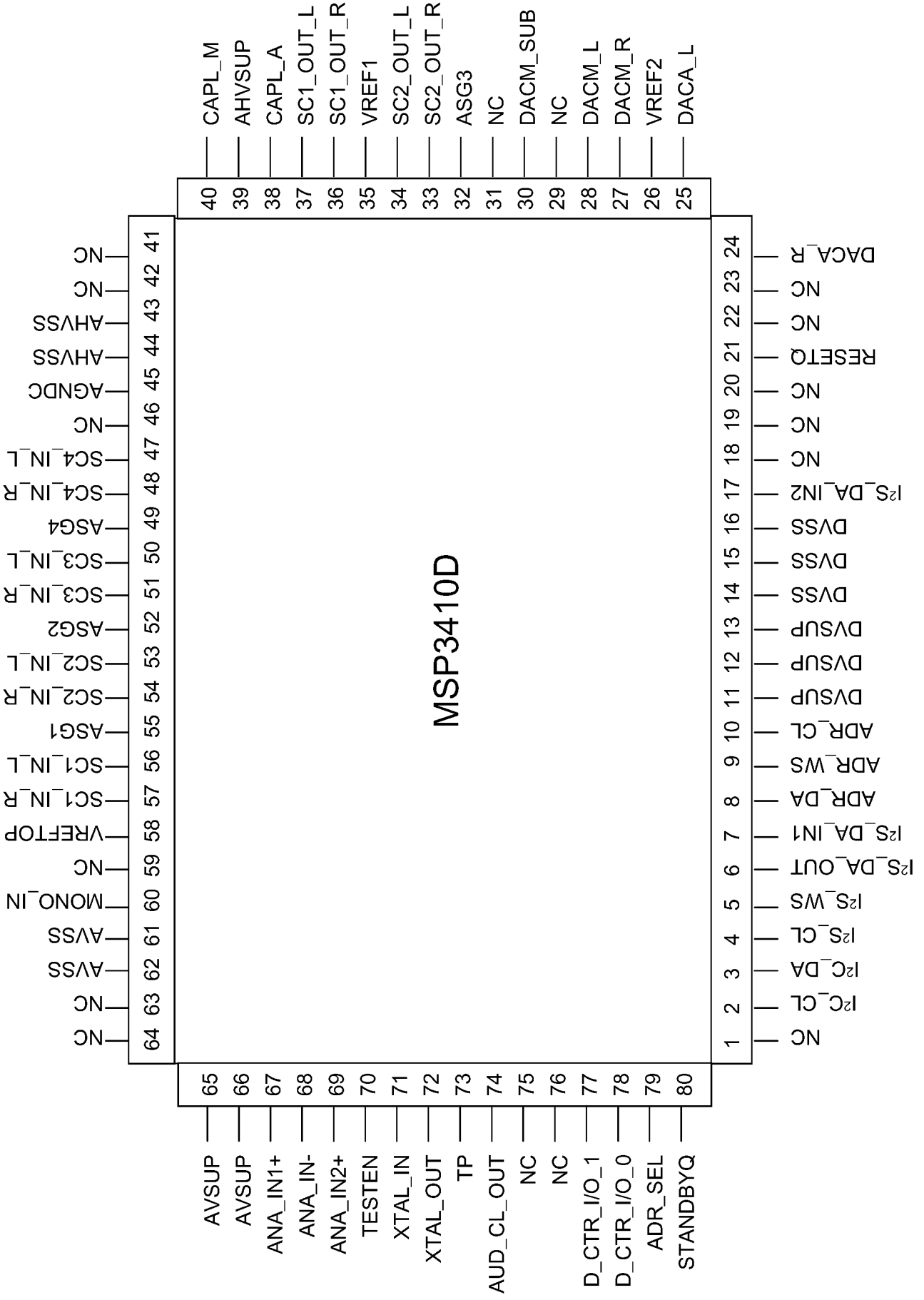

## Audio Processing - MSP3410D

Pin No.	Pin Name	Type	Short Description
1	NC		Not connected
2	I2C_CL	IN/OUT	I2C clock
3	I2C_DA	IN/OUT	I2C data
4	I2S_CL	IN/OUT	I2S clock
5	I2S_WS	IN/OUT	I2S word strobe
6	I2S_DA_O	OUT	I2S data output
7	I2S_DA_IN	IN	I2S1 data input
8	ADR_DA	OUT	ADR data output
9	ADR_WS	OUT	ADR word strobe
10	ADR_CL	SUPPLYD	Supply Voltage, Digital Circuitry
11	DVSUP	SUPPLYD	Ground, Digital Circuitry
12	DVSUP	SUPPLYD	Ground
13	DVSUP	IN/OUT	I 2 C Bus Clock
14	DVSS	IN/OUT	I 2 C Bus Data
15	DVSS	IN	Reset Input, Active Low
16	DVSS	IN	Test Pin, connect to GND D
17	I2S_DA_IN	IN	VGAV Input
18	NC	IN	Y/C Output Enable Input, Active Low
19	NC	OUT	FIFO Input Enable
20	NC	OUT	FIFO Write Enable
21	RESET_Q	OUT	FIFO Reset Write/Read
22	NC	OUT	FIFO Read Enable
23	NC	OUT	FIFO Output Enable
24	DACA_R	IN/OUT	Main Clock Output 20.25 MHz
25	DACA_R	SUPPLYD	Ground

Pin No.	Pin Name	Type	Short Description
26	V SUPPA	SUPPLYD	Supply Voltage
27	LLC2	OUT	Double Clock Output
28	LLC1	IN/OUT	Clock Output
29	V SUPLLC	SUPPLYD	Supply Voltage, LLC Circuitry
30	GND LLC	SUPPLYD	Ground, LLC Circuitry
31	Y7	OUT	Picture Bus Luma (MSB)
32	Y6	OUT	Picture Bus Luma
33	Y5	OUT	Picture Bus Luma
34	Y4	OUT	Picture Bus Luma
35	GND Y	SUPPLYD	Ground, Luma Output Circuitry
36	V SUPY	SUPPLYD	Supply Voltage, Luma Output Circuitry
37	Y3	OUT	Y Picture Bus Luma
38	Y2	OUT	Y Picture Bus Luma
39	Y1	OUT	Y Picture Bus Luma
40	Y0	OUT	Y Picture Bus Luma(LSB)
41	C7	OUT	Picture Bus Chroma (MSB)
42	C6	OUT	Picture Bus Chroma
43	C5	OUT	Picture Bus Chroma
44	C4	OUT	Picture Bus Chroma
45	V SUPC	SUPPLYD	Supply Voltage, Chroma Output Circuitry
46	GND C	SUPPLYD	Ground, Chroma Output Circuitry
47	C3	OUT	Picture Bus Chroma
48	C2	OUT	Picture Bus Chroma
49	C1	OUT	Picture Bus Chroma
50	C0	OUT	Picture Bus Chroma(LSB)

# Audio Processing - MSP3440G

Pin No.	Pin Name	Type	Short Description
51	GND SY	SUPPLYD	Ground, Sync Pad Circuitry
52	V SUPSY	SUPPLYD	Supply Voltage, Sync Pad Circuitry
53	INTLC	OUT	Interlace Output
54	AVO	OUT	Active Video Output
55	FSY/HC	OUT	Front Sync/ Horizontal Clamp Pulse
56	MSY/HS	IN/OUT	Main Sync/Horizontal Sync Pulse
57	SC1_in_R	IN	SCART 1 input, right
58	VREFTOP		Reference voltage IF A/D converter
59	NC		Not connected
60	MONO_IN	IN	Mono input
61	AVSS		Analog ground
62	AVSS		Analog ground
63	NC		Not connected
64	NC		Not connected
65	AVSUP		Analog power supply 5V
66	AVSUP		Analog power supply 5V
67	ANA_IN+	IN	IF input 1
68	ANA_IN-	IN	IF common{can be left vacant, only if IF input1 is also not in use}
69	ANA_IN2+	IN	IF input{can be left vacant, only if IF input1 is also not in use}
70	TESTEN	IN	Test pin
71	XTAL_IN	IN	Crystal oscillator

Pin No.	Pin Name	Type	Short Description
72	XTAL_OUT	OUT	Crystal oscillator
73	TP		Test pin
74	AUD_CLK	OUT	Audio clock output(18.432MHz)
75	NC		Not connected
76	NC		Not connected
77	D_CTR_I/O_1	IN/OUT	D_CTR_I/O_1
78	D_CTR_I/O_0	IN/OUT	D_CTR_I/O_0
79	ADR_SEL	IN	I2C Bus address select
80	STANDBY	IN	Stand-by(low active)

# LM2576

## 3.0 A, 15 V, Step-Down Switching Regulator

The LM2576 series of regulators are monolithic integrated circuits ideally suited for easy and convenient design of a step-down switching regulator (buck converter). All circuits of this series are capable of driving a 3.0 A load with excellent line and load regulation. These devices are available in fixed output voltages of 3.3 V, 5.0 V, 12 V, 15 V, and an adjustable output version.

These regulators were designed to minimize the number of external components to simplify the power supply design. Standard series of inductors optimized for use with the LM2576 are offered by several different inductor manufacturers.

Since the LM2576 converter is a switch-mode power supply, its efficiency is significantly higher in comparison with popular three-terminal linear regulators, especially with higher input voltages. In many cases, the power dissipated is so low that no heatsink is required or its size could be reduced dramatically.

A standard series of inductors optimized for use with the LM2576 are available from several different manufacturers. This feature greatly simplifies the design of switch-mode power supplies.

The LM2576 features include a guaranteed  $\pm 4\%$  tolerance on output voltage within specified input voltages and output load conditions, and  $\pm 10\%$  on the oscillator frequency ( $\pm 2\%$  over  $0^{\circ}\text{C}$  to  $125^{\circ}\text{C}$ ). External shutdown is included, featuring  $80\ \mu\text{A}$  (typical) standby current. The output switch includes cycle-by-cycle current limiting, as well as thermal shutdown for full protection under fault conditions.

### Features

- 3.3 V, 5.0 V, 12 V, 15 V, and Adjustable Output Versions
- Adjustable Version Output Voltage Range, 1.23 to 37 V  $\pm 4\%$  Maximum Over Line and Load Conditions
- Guaranteed 3.0 A Output Current
- Wide Input Voltage Range
- Requires Only 4 External Components
- 52 kHz Fixed Frequency Internal Oscillator
- TTL Shutdown Capability, Low Power Standby Mode
- High Efficiency
- Uses Readily Available Standard Inductors
- Thermal Shutdown and Current Limit Protection
- Moisture Sensitivity Level (MSL) Equals 1

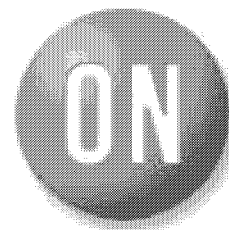

ON Semiconductor™

<http://onsemi.com>

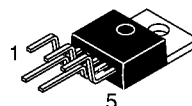

TO-220  
TV SUFFIX  
CASE 314B

Heatsink surface connected to Pin 3

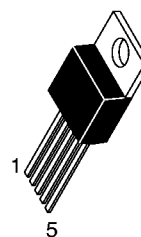

TO-220  
T SUFFIX  
CASE 314D

- Pin
1.  $V_{in}$
  2. Output
  3. Ground
  4. Feedback
  5. ON/OFF

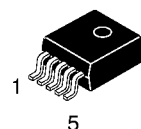

D<sup>2</sup>PAK  
D2T SUFFIX  
CASE 936A

Heatsink surface (shown as terminal 6 in case outline drawing) is connected to Pin 3

# LM2576

## Typical Application (Fixed Output Voltage Versions)

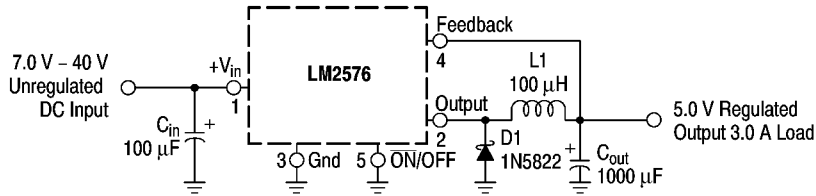

## Representative Block Diagram and Typical Application

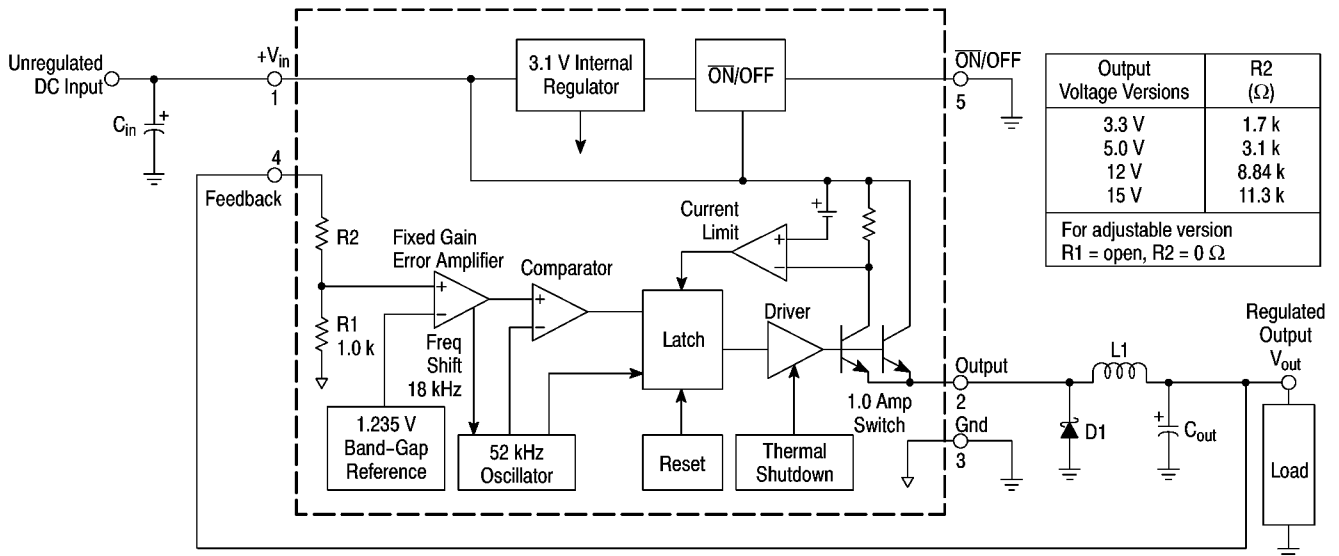

# FDS9933A

## Dual P-Channel 2.5V Specified PowerTrench™ MOSFET

### General Description

These P-Channel 2.5V specified MOSFETs are produced using Fairchild Semiconductor's advanced PowerTrench process that has been especially tailored to minimize the on-state resistance and yet maintain low gate charge for superior switching performance.

### Applications

- Load switch
- DC/DC converter
- Motor drives

### Features

- -3.8 A, -20 V.  $R_{DS(on)} = 0.075 \Omega @ V_{GS} = -4.5 V$   
 $R_{DS(on)} = 0.105 \Omega @ V_{GS} = -2.5 V$ .
- Low gate charge ( 7nC typical ).
- Fast switching speed.
- High performance trench technology for extremely low  $R_{DS(on)}$ .
- High power and current handling capability.

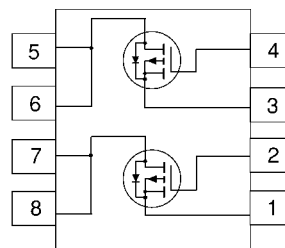
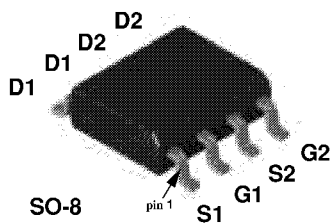

# DS90C383A/DS90CF383A

## +3.3V Programmable LVDS Transmitter 24-Bit Flat Panel Display (FPD) Link-65 MHz

## +3.3V LVDS Transmitter 24-Bit Flat Panel Display (FPD) Link-65 MHz

### 1.0 General Description

The DS90C383A/DS90CF383A transmitter converts 28 bits of CMOS/TTL data into four LVDS (Low Voltage Differential Signaling) data streams. A phase-locked transmit clock is transmitted in parallel with the data streams over a fifth LVDS link. Every cycle of the transmit clock 28 bits of input data are sampled and transmitted. At a transmit clock frequency of 65 MHz, 24 bits of RGB data and 3 bits of LCD timing and control data (FPLINE, FPFRAME, DRDY) are transmitted at a rate of 455 Mbps per LVDS data channel. Using a 65 MHz clock, the data throughput is 227 Mbytes/sec. The DS90C383A transmitter can be programmed for Rising edge strobe or Falling edge strobe through a dedicated pin. The DS90CF383A is fixed as a Falling edge strobe transmitter. A Rising edge or Falling edge strobe transmitter will interoperate with a Falling edge strobe Receiver (DS90CF384) without any translation logic.

This chipset is an ideal means to solve EMI and cable size problems associated with wide, high speed TTL interfaces.

### 2.0 Features

- 20 to 65 MHz shift clock support
- Rejects  $> \pm 3$ ns Jitter from VGA chip with less than 225ps output Jitter @65MHz (TJCC)
- Best-in-Class Set & Hold Times on TxINPUTs
- Tx power consumption  $< 130$  mW (typ) @65MHz Grayscale
- $> 50\%$  Less Power Dissipation than BiCMOS Alternatives
- Tx Power-down mode  $< 200\mu$ W (max)
- ESD rating  $> 7$  kV (HBM),  $> 500$ V (EIAJ)
- Supports VGA, SVGA, XGA and Dual Pixel SXGA.
- Narrow bus reduces cable size and cost
- Up to 1.8 Gbps throughput
- Up to 227 Megabytes/sec bandwidth
- 345 mV (typ) swing LVDS devices for low EMI
- PLL requires no external components
- Compatible with TIA/EIA-644 LVDS standard
- Low profile 56-lead TSSOP package
- Improved replacement for:
  - SN75LVDS83 — DS90C383A
  - SN75LVDS81 — DS90CF383A

### 3.0 Block Diagrams

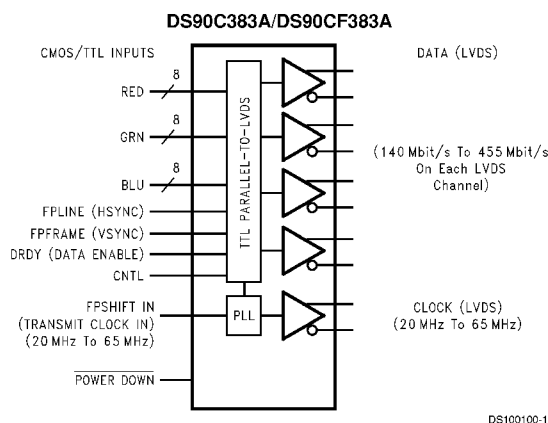

Order Number DS90C383AMTD or DS90CF383AMTD  
See NS Package Number MTD56



# Specification Inverter GH017

## 2. SUITABLE LOAD

LCD-Module: Samsung 17"E4 4lamp TFT LCD

## 3. ELECTRICAL CHARACTERISTICS

### 3.1 Absolute Maximum Ratings

Item	Symbol	Spec	Unit
Input voltage 1	Vin1	11.5 ~ 12.5	V
Input voltage 2	Vin2	4.9 ~ 5.1	V
Operating Temperature	Top	0 ~ 50	°C
Storage Temperature	Tstg	- 30 ~ 80	°C
Relative Humidity	RH	90	%

### 3.2 Control Signal

Pin No.	Symbol	Status	Action	Remarks
CN1 # 4	BKLT_ON	HIGH	LAMP (CCFL) - ON	2.4 ~ 5.25V
		LOW	LAMP (CCFL) - OFF	0.8V max.

## 5. APPEARANCE

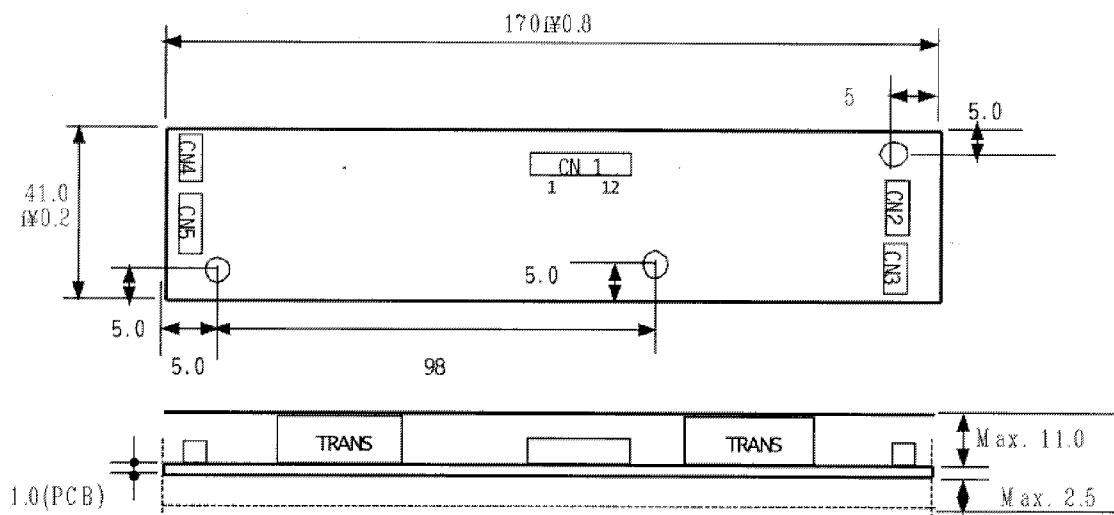

## 4. INTERFACE

### 4.1 CN1 Connector: 53261 – 1290

Pin No.	Symbol	Remarks
2	BRT_ADJ	0 ~ 5V
1,3,5,6,8,9	GND	GND
4	BL ON / OFF	CCFL drive signal (active HIGH)
7	N.C	
10,11,12	DC-IN (V in)	DC INPUT power (12V)

### 4.2 CN2 Connector: SM02B – BHS – 1 – TB(JST)

Pin No.	Symbol	Remarks
1	HOT	HIGH
2	COLD	LOW

### 4.3 CN3 Connector: SM02B – BHS – 1 – TB(JST)

Pin No.	Symbol	Remarks
1	HOT	HIGH
4	COLD	LOW

### 4.4 CN4 Connector: SM02B – BHS – 1 – TB(JST)

Pin No.	Symbol	Remarks
1	HOT	HIGH
4	COLD	LOW

### 4.5 CN5 Connector: SM02B – BHS – 1 – TB(JST)

Pin No.	Symbol	Remarks
1	HOT	HIGH
4	COLD	LOW

## SERVICE ADJUSTMENTS AND OPTIONS

**Entering the service mode:** In TV mode ,Press Menu key and enter “9301”.

**Exiting from service mode:** Press “TV/TX” key (SW version is prompted when exiting from service mode)

**Navigation:** P+/P- moves upward / downward inside the service menu.  
V+/V- changes the values or options

**Sevice menu sub pages:** Press Red, Green or Blues key to access sub pages of service mode

### Feature Options

TUNER	: TEMIC, P.SONIC, SHARP&ALPS, PHILIPS
TELETEXT	: DEFAULT -Teletext FASTEXT-Fasttext TOPTTEXT- Toptext TOP&FAST : Toptext and Fasttext
SWAP / ZAP:	SWAP- Swap is active ZAP: Zap is active
STAND BY:	YES- User mode NO: Factory mode
VIDEO	: OLD, NEW-No function
MONITOR	: Yes (Monitor connection is available) : No (Monitor connection is not supported)
LANGUAGE	: Used to select the menu language.  GROUP 0 : (English, German, French, Itailan, Spanish, Turkish , Swiss , Norwegian, Danish, Finnish , Dutch, Polish, Greek, Bulgarian, Russian, Hebrew)  GROUP 1: ( English,German, French, Itailan, Spanish, Turkish ,Swiss, Hungary, Polish, Romanian, Croatian , Slovenian, Greek, Bulgarian, Russian, Arabian)

BG : Yes (AVAILABLE) or No (NOT AVAILABLE)  
 DK : Yes (AVAILABLE) or No (NOT AVAILABLE)  
 I : Yes (AVAILABLE) or No (NOT AVAILABLE)  
 L/L' : Yes (AVAILABLE) or No (NOT AVAILABLE)  
 NICAM : Yes (AVAILABLE) or No (NOT AVAILABLE)  
 HEADPHONE : Yes (AVAILABLE) or No (NOT AVAILABLE)

CARRIER MUTE : VIA MSP (Default)  
 VIA MICRO

### Factory Settings for Service Mode

ITEM	FUNCTION	FACTORY VALUE
<b>AGC</b>	<b>AUTOMATIC GAIN CONTROL</b>	<b>2</b>
<b>R-CUT</b>	<b>RED CUT OF ADJUSTMENT</b>	<b>2</b>
<b>G-CUT</b>	<b>GREEN CUT OF ADJUSTMENT</b>	<b>0</b>
<b>B-CUT</b>	<b>BLUE CUT OF ADJUSTMENT</b>	<b>0</b>
<b>R.DRV</b>	<b>RED DRIVE ADJUSMENT</b>	<b>0</b>
<b>G.DRV</b>	<b>GREEN DRIVE ADJUSMENT</b>	<b>0</b>
<b>B.DRV</b>	<b>BLUE DRIVE ADJUSMENT</b>	<b>0</b>
<b>BACKLIGHT</b>	<b>BACK LIGHT ADJUSTMENT</b>	<b>0</b>

## WAVEFORMS

**Note :** TV is connected to a pattern generator with colour bar signal and L=3KHz, R=1KHz

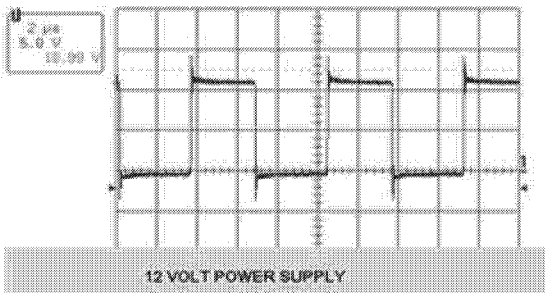
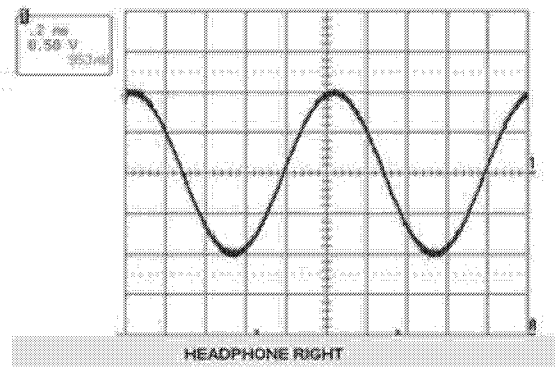
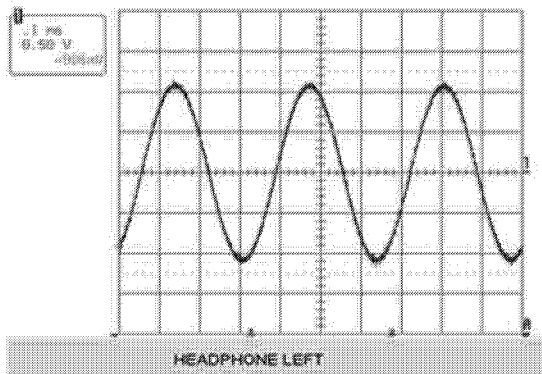
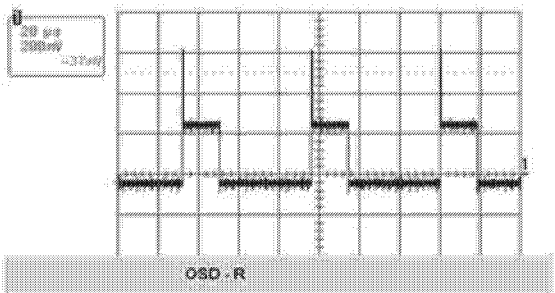
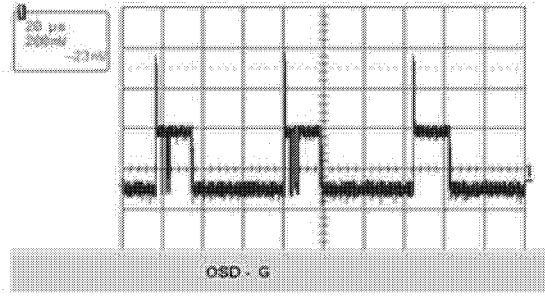
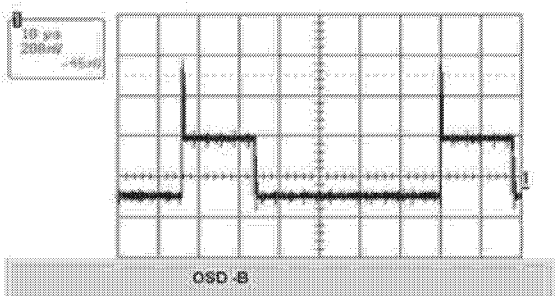
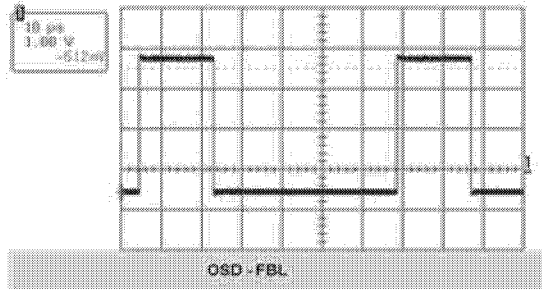
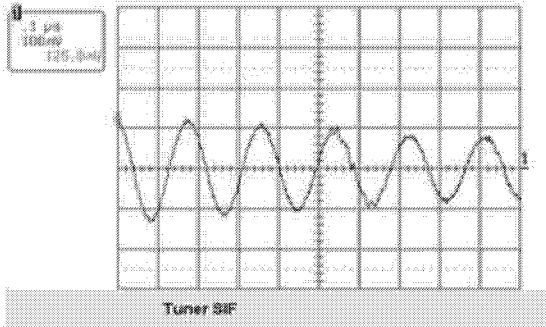

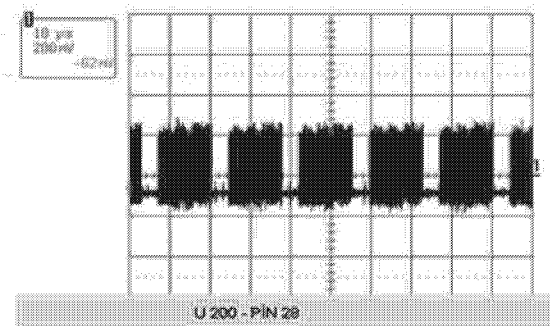
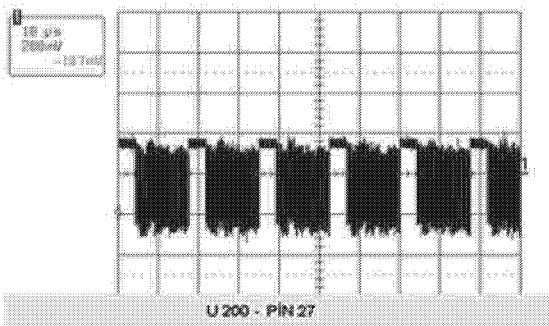
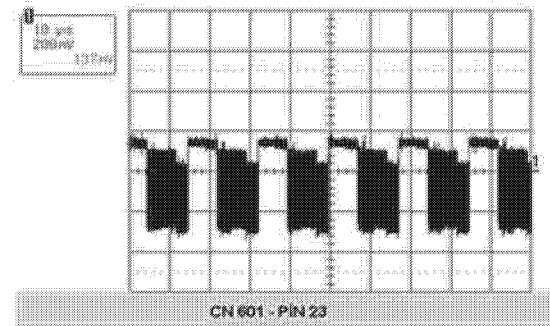
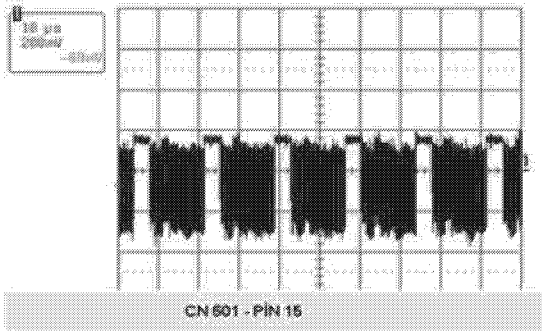
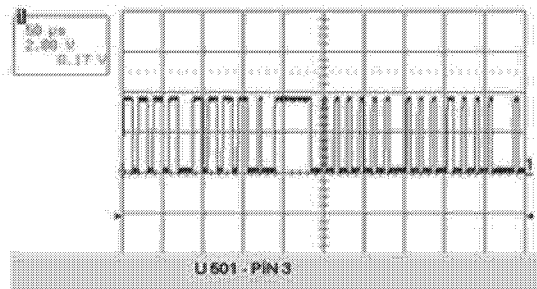
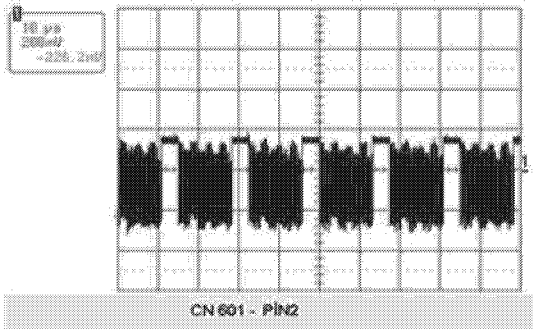
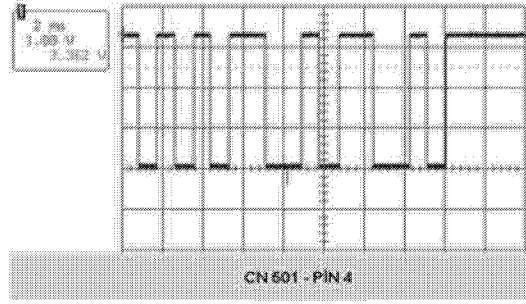
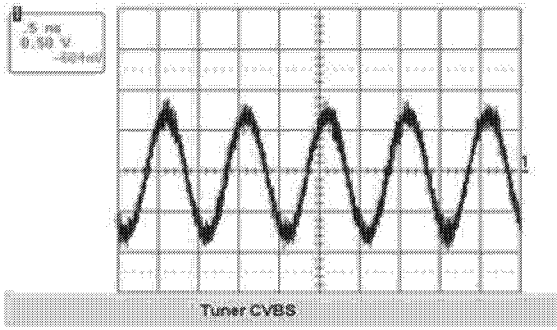

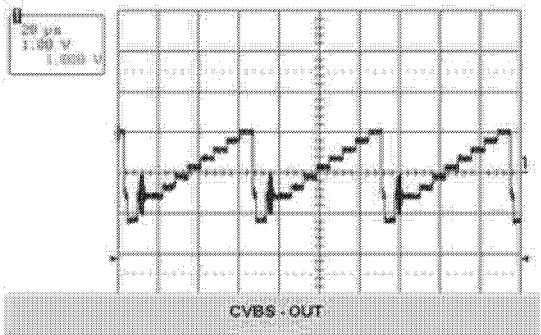
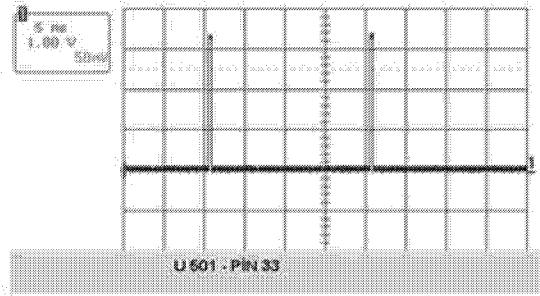
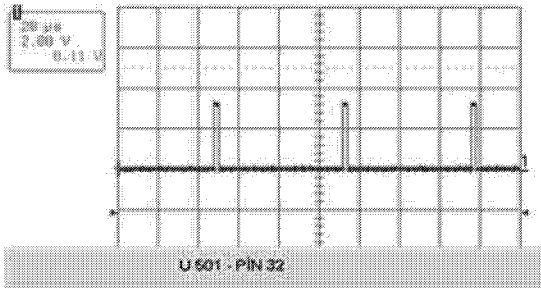
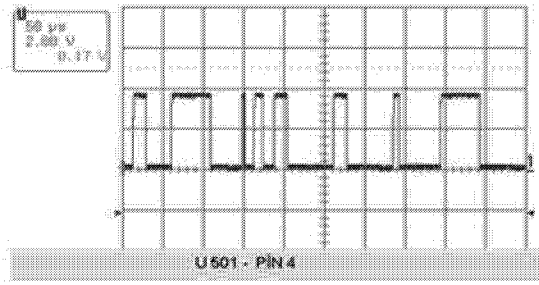
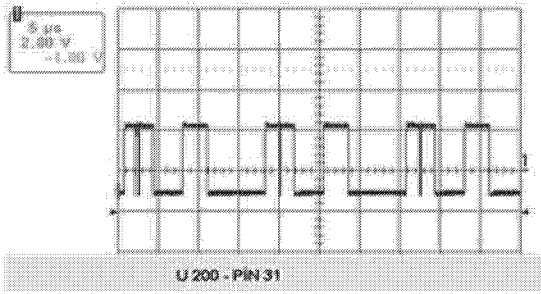

## SPARE PART LIST

POSITION	PART NUMBER	PART DESCRIPTION
SW1	010717	POWER SWITCH SPEA121800 ALPS
MENU	010844	TACT SWITCH 2 LEG (MTSB)
P(+)	010844	TACT SWITCH 2 LEG (MTSB)
P(-)	010844	TACT SWITCH 2 LEG (MTSB)
V(+)	010844	TACT SWITCH 2 LEG (MTSB)
V(-)	010844	TACT SWITCH 2 LEG (MTSB)
CN103	031163	KONN. CINCH ..... WHITE HOR.14.1
CN110	031163	KONN. CINCH ..... WHITE HOR.14.1
CN102	031164	KONN. CINCH ..... RED HOR.14.1
CN111	031164	KONN. CINCH ..... RED HOR.14.1
CN101	031165	KONN. CINCH ..... YELLOW HOR.14.1
CN104	031251	SCART SOCKET 14.1
CN900	031274	JACK POWER HORIZONTAL
CN502	031277	KON.MALE 12 PIN MOLEX 53261-1290 T&R
CN301	031358	CONN. VGA B10B
CN100	031795	KONN.S-VHS
F900	054290	FUSE 5.0A 250V ROUND
L106	055552	CORE FERRITE BFD3565R2F
D903	055571	FERRITE 5*2*8
X400	056161	CRYSTAL 20.25MHZ HC49-U
Q01	056210	CER.RESONATOR GSB455E
X600	056942	KRISTAL 24MHZ
X100	056952	CRYSTAL 18.432MHZ +-30PPM
X500	056953	CRYSTAL 6MHZ CL 20PF
C900	252683	EC 680UF 35V 20*12.5 R:5 LOW ESR
D1	302409	LED BLUE
D903	303180	DIODE 1N5820 SCHOTTKY
D500	303189	DIODE BAS40-05 SCHOTTKY
D501	303196	DIODE BAS40 SCHOTTKY
D900	303345	DIODE MRA4003T3
D901	303345	DIODE MRA4003T3
D902	303345	DIODE MRA4003T3
D01	303991	LED IR SIR563SB3F 23/940
D02	303993	LED LTL4221N D:3 R/D RED
Q500	401371	TRN 2N7002
Q501	401371	TRN 2N7002
U701	401372	TRN FDS9933A
U906	401372	TRN FDS9933A
U1	450517	IC CHIP MMSF7P03HDR2
IC01	452382	IC-CHIP S3C1840DA9/SMB1 T&R
IR1	452521	IR RECEIVER TSOP 1838
U102	452904	IC LM78L08ACZ
U400	452937	IC-CHIP VPC3230D-C5 QFP80 T&R
U401	452985	IC-CHIP MC14053BD SOIC16
U505	453001	IC M29W040B70N1T



POSITION	PART NUMBER	PART DESCRIPTION
U600	453004	IC GM5020
U502	453006	IC K6X1008T2D-TF70
U900	453007	IC LM2596S-5.0
U901	453008	IC LP3962ES-2.5
U902	453009	IC LP3962ES-3.3
U300	453010	IC M24C02-MN1T
	453013	IC SDA5550 PLCC-84 TRAY
U200	453018	IC DS90C383AMTD
U103	453021	IC TDA1517P
U503	453024	IC MC33375ST-2.5T3
U203	453025	IC MC33375ST-3.3T3
U504	453025	IC MC33375ST-3.3T3
U101	453026	IC-CHIP MSP3410G PQFP80 T&R
U500	453028	IC DS1818R-10/T&R
U800	453101	IC K4S161622E-TC70
U801	453101	IC K4S161622E-TC70
U802	453101	IC K4S161622E-TC70
	600303	TERMINAL BATT.BOX(+/-) R/C
	056L15-SS1	LCD SAMSUNG LTM150XH-L06A (LCD TV)
U506	452662-02	IC-CHIP AT24C16AN 10SI2.7 TAPE&REEL
	7XB301	TERMINAL BATT.BOX(+) R/C FLAT
	7XB302	TERMINAL BATT.BOX(-) R/C FLAT
	7XB901	RUBBER CONTACT PURE FLAT COMMON 14.1
	8R8138	TUNER FRONTEND PHILIPS FQ1216ME
X941	8R9185	HP JACK 17"LCD TV
	8R9185-KV	MODULE ASSY LCD TV
	8R9913	ADAPTOR AC12V 5A SUPERWORLD LAD6019AB5
	L05172	CU ASSY 15L2L02
	L05201F	FRONT COVER 15"L02 LCD TV SILVER
	L05251	FRONT COVER SIL.P.BEKO P/V 15" LCD TV
	L05800-00A	GIFT BOX BEKO/PI.15L2L02 PI/NX/2/K/S/VGA
	S01903	CUSHION 28T39/T40/T47
	S89187F	RC FLAT B-TYPE SMART C/TV/PC S.LI SI.VGA
U501	SL2150-01	SW/IC SDA5550 PLCC-84 TRAY 15" LCD TV
	X60110	L2 CHASIS 15"LCD TV PI/NX/2/K/SV/VGA A-O
	X60183-SS1	INVERTOR CARD 15" LCDTV GREENTECH SS1
	X60205-03F	BACK COVER 15L02 LCDTV MET.DARK BLUE VGA
	X60206F	SCART BACK COVER 15" LCD TV MET.DA.BLUE
	X60212F	KNOB PROGRAM VOLUME 15" LCD TV SILVER
	X60256	SCART COVER ME.DARK B PAINTED 15" L15
	X60262	KNOB PROGRAM VOLUME SILVER 15" LCDTV
	X60388	CUSHION SCREEN 15" LCD TV LONG SIDE
CN601	X60502-AS	CABLE PANEL INTERFACE LCD TV 15"
	X60805	CUSHION LEFT 15" LCD TV
	X60806	CUSHION RIGHT 15" LCD TV
	ZH1204F	LENS IR/LED 15"L02 LCD TV
	ZH1258	POWER KNOB SILVER PAINTED 15"L02 LCD TV

## FREQUENCY TABLE (MHz)

Channel	Number	BG	I	DK	L/L'
CH	1		49.75	49.75	47.75
CH	2	48.25	59.25	59.25	55.75
CH	3	55.25	77.25	77.25	60.50
CH	4	62.25	85.25	85.25	63.75
CH	5	175.25	93.25	93.25	176.00
CH	6	182.25	175.25	175.25	184.00
CH	7	189.25	183.25	183.25	192.00
CH	8	196.25	191.25	191.25	200.00
CH	9	203.25	199.25	199.25	208.00
CH	10	210.25	207.25	207.25	216.00
CH	11	217.25	215.25	215.25	189.25
CH	12	224.25	223.25	223.25	182.25
CH	13	53.75	45.75		196.25
CH	14	62.25	53.75		210.25
CH	15	82.25	61.75		
CH	16	175.25	69.75		
CH	17	183.25	95.25		
CH	18	192.25			
CH	19	201.25			
CH	20	210.25			
CH	21	471.25	471.25	471.25	471.25
CH	22	479.25	479.25	479.25	479.25
CH	23	487.25	487.25	487.25	487.25
CH	24	495.25	495.25	495.25	495.25
CH	25	503.25	503.25	503.25	503.25
CH	26	511.25	511.25	511.25	511.25
CH	27	519.25	519.25	519.25	519.25
CH	28	527.25	527.25	527.25	527.25
CH	29	535.25	535.25	535.25	535.25
CH	30	543.25	543.25	543.25	543.25
CH	31	551.25	551.25	551.25	551.25
CH	32	559.25	559.25	559.25	559.25
CH	33	567.25	567.25	567.25	567.25
CH	34	575.25	575.25	575.25	575.25
CH	35	583.25	583.25	583.25	583.25
CH	36	591.25	591.25	591.25	591.25
CH	37	599.25	599.25	599.25	599.25
CH	38	607.25	607.25	607.25	607.25
CH	39	615.25	615.25	615.25	615.25
CH	40	623.25	623.25	623.25	623.25
CH	41	631.25	631.25	631.25	631.25
CH	42	639.25	639.25	639.25	639.25
CH	43	647.25	647.25	647.25	647.25
CH	44	655.25	655.25	655.25	655.25

<b>Channel</b>	<b>Number</b>	<b>BG</b>	<b>I</b>	<b>DK</b>	<b>L/L'</b>
CH	45	663.25	663.25	663.25	663.25
CH	46	671.25	671.25	671.25	671.25
CH	47	679.25	679.25	679.25	679.25
CH	48	687.25	687.25	687.25	687.25
CH	49	695.25	695.25	695.25	695.25
CH	50	703.25	703.25	703.25	703.25
CH	51	711.25	711.25	711.25	711.25
CH	52	719.25	719.25	719.25	719.25
CH	53	727.25	727.25	727.25	727.25
CH	54	735.25	735.25	735.25	735.25
CH	55	743.25	743.25	743.25	743.25
CH	56	751.25	751.25	751.25	751.25
CH	57	759.25	759.25	759.25	759.25
CH	58	767.25	767.25	767.25	767.25
CH	59	775.25	775.25	775.25	775.25
CH	60	783.25	783.25	783.25	783.25
CH	61	791.25	791.25	791.25	791.25
CH	62	799.25	799.25	799.25	799.25
CH	63	807.25	807.25	807.25	807.25
CH	64	815.25	815.25	815.25	815.25
CH	65	823.25	823.25	823.25	823.25
CH	66	831.25	831.25	831.25	831.25
CH	67	839.25	839.25	839.25	839.25
CH	68	847.25	847.25	847.25	847.25
CH	69	855.25	855.25	855.25	855.25
CH	70		863,25		863.25
CH	71		871,25		
CH	72		879,25		
CH	73		887,25		160.00
CH	74	69.25			172.00
CH	75	76.25			220.00
CH	76	83.25			232.00
CH	77	90.25			244.00
CH	78	97.25			256.00
CH	79	59.25			268.00
CH	80	93.25			280.00
S	1	105.25	103.25	103.25	116.75
S	2	112.25	111.25	111.25	128.75
S	3	119.25	119.25	119.25	140.75
S	4	126.25	127.25	127.25	152.75
S	5	133.25	135.25	135.25	164.75
S	6	140.25	143.25	143.25	176.75
S	7	147.25	151.25	151.25	188.75
S	8	154.25	159.25	159.25	200.75
S	9	161.25	167.25	167.25	212.75
S	10	168.25	231.25	231.25	224.75
S	11	231.25	239.25	239.25	236.75
S	12	238.25	247.25	247.25	248.75
S	13	245.25	255.25	255.25	260.75
S	14	252.25	263.25	263.25	272.75

<b>Channel</b>	<b>Number</b>	<b>BG</b>	<b>I</b>	<b>DK</b>	<b>L/L'</b>
S	15	259.25	271.25	271.25	284.75
S	16	266.25	279.25	279.25	296.75
S	17	273.25	287.25	287.25	55.75
S	18	280.25	295.25	295.25	60.50
S	19	287.25	303.25	303.25	63.75
S	20	294.25			
S	21	303.25			303.25
S	22	311.25	311.25	311.25	311.25
S	23	319.25	319.25	319.25	319.25
S	24	327.25	327.25	327.25	327.25
S	25	335.25	335.25	335.25	335.25
S	26	343.25	343.25	343.25	343.25
S	27	351.25	351.25	351.25	351.25
S	28	359.25	359.25	359.25	359.25
S	29	367.25	367.25	367.25	367.25
S	30	375.25	375.25	375.25	375.25
S	31	383.25	383.25	383.25	383.25
S	32	391.25	391.25	391.25	391.25
S	33	399.25	399.25	399.25	399.25
S	34	407.25	407.25	407.25	407.25
S	35	415.25	415.25	415.25	415.25
S	36	423.25	423.25	423.25	423.25
S	37	431.25	431.25	431.25	431.25
S	38	439.25	439.25	439.25	439.25
S	39	447.25	447.25	447.25	447.25
S	40	455.25	455.25	455.25	455.25
S	41	463.25	463.25	463.25	463.25



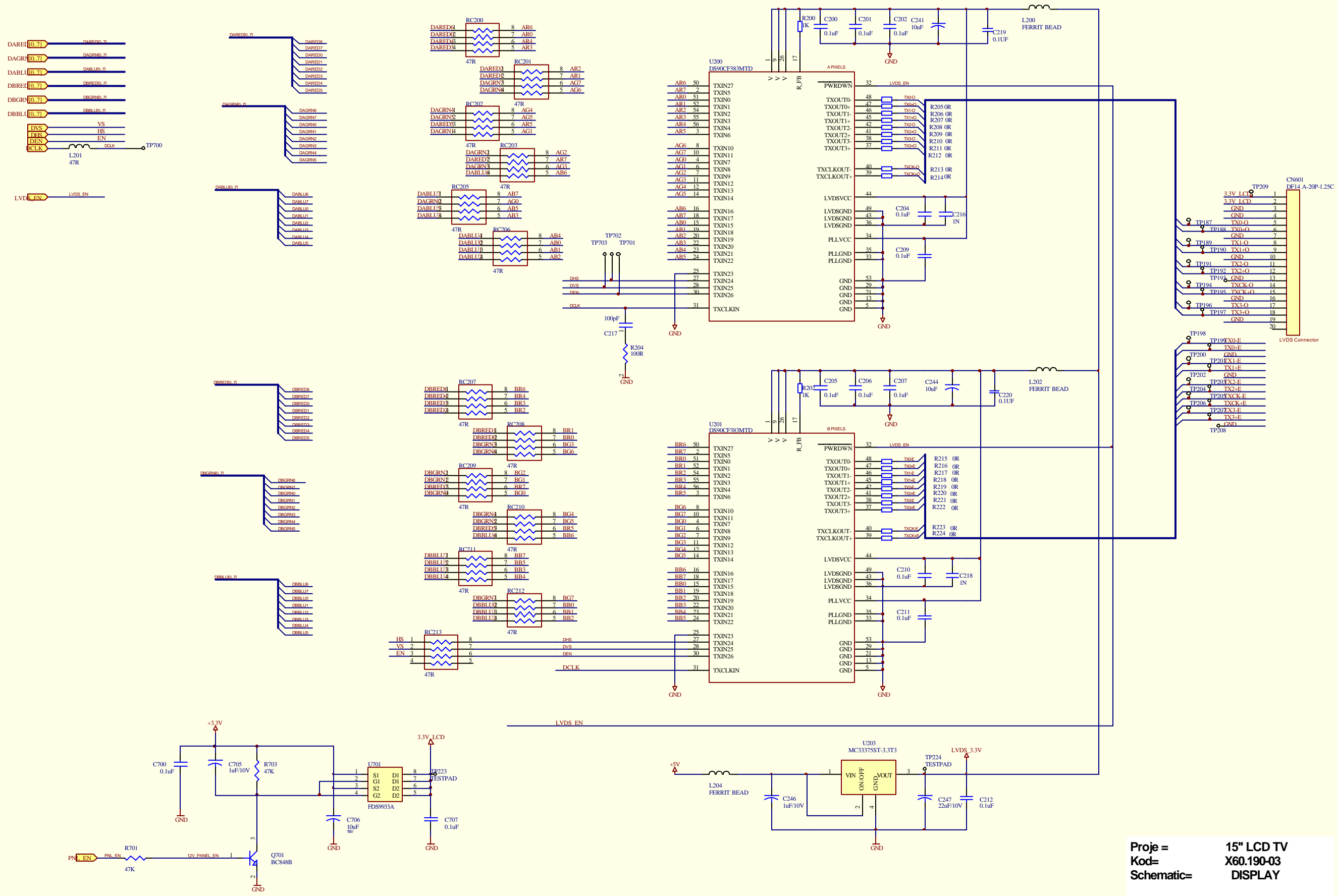

Proje = 15" LCD TV  
 Kod= X60.190-03  
 Schematic= DISPLAY

Beko Elektronik A.S.		
Size C	Title 5. Display	Rev A
Document Number	Control	
Date	24-Sep-2003	Sheet 7 of 9

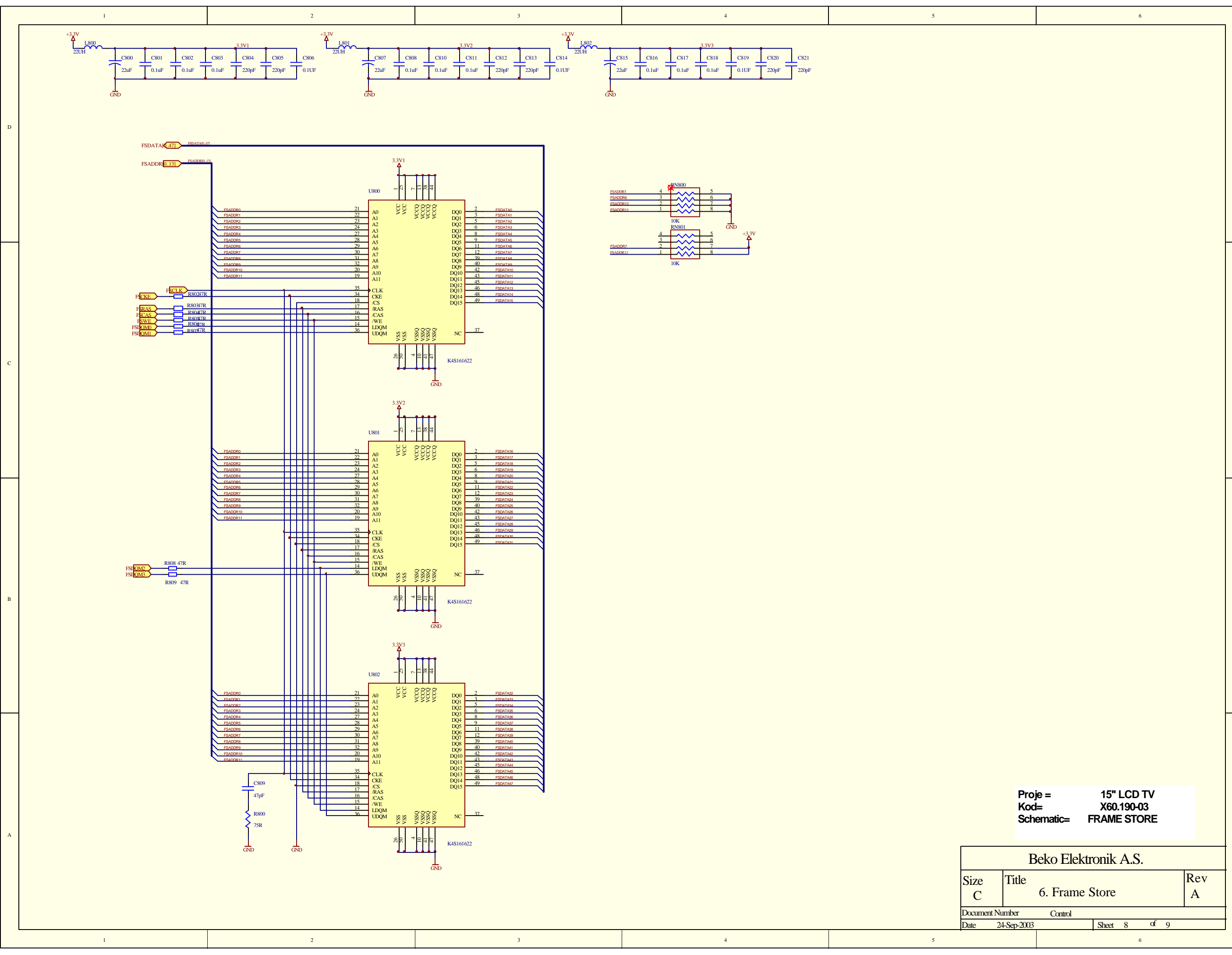

Proje = 15" LCD TV  
 Kod= X60.190-03  
 Schematic= FRAME STORE

Beko Elektronik A.S.		
Size C	Title 6. Frame Store	Rev A
Document Number Control		Date 24-Sep-2003
Date 24-Sep-2003		Sheet 8 of 9

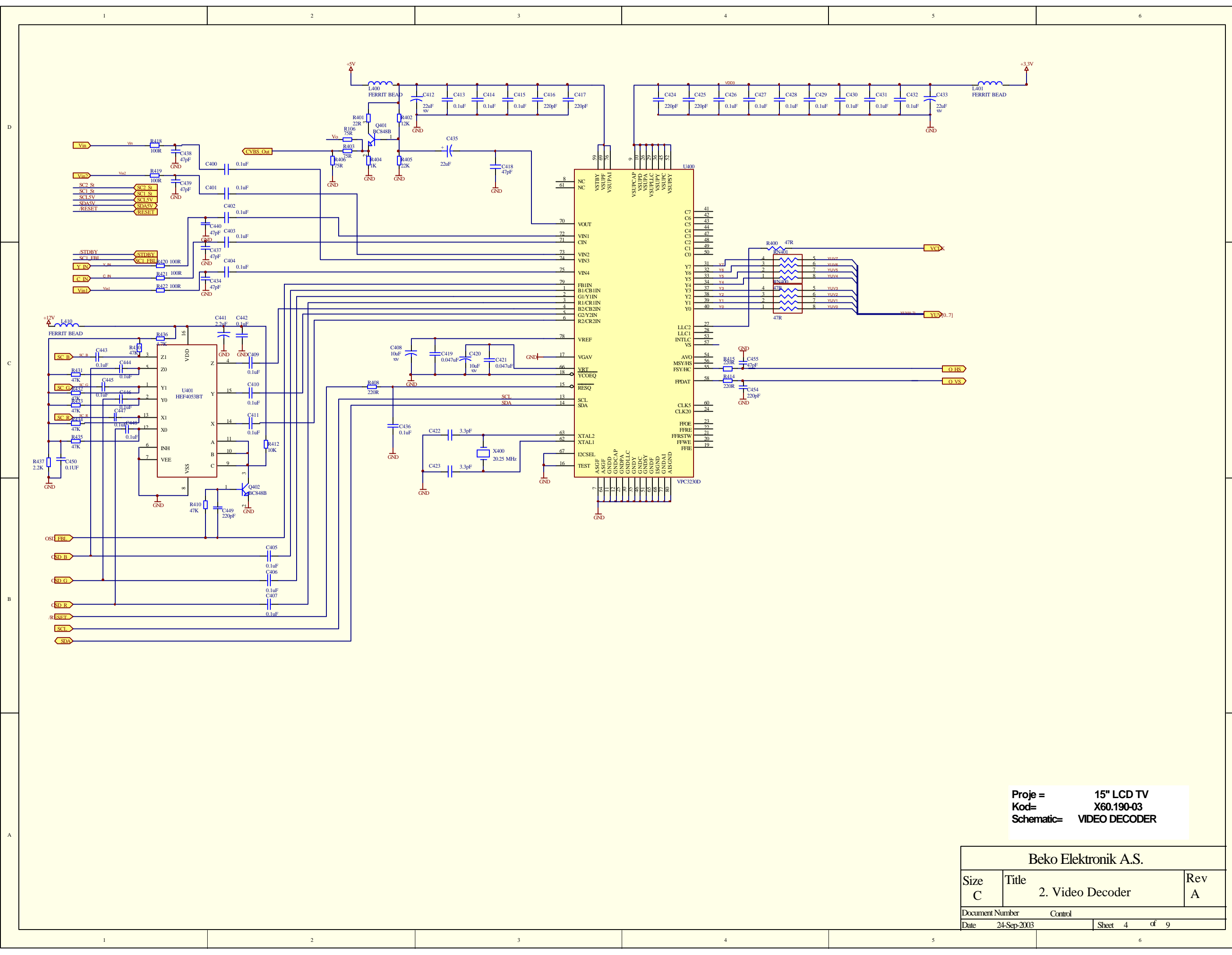

Proje = 15" LCD TV  
 Kod= X60.190-03  
 Schematic= VIDEO DECODER

Beko Elektronik A.S.		
Size C	Title 2. Video Decoder	Rev A
Document Number Control		
Date 24-Sep-2003	Sheet 4	d' 9



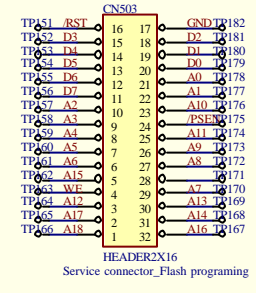
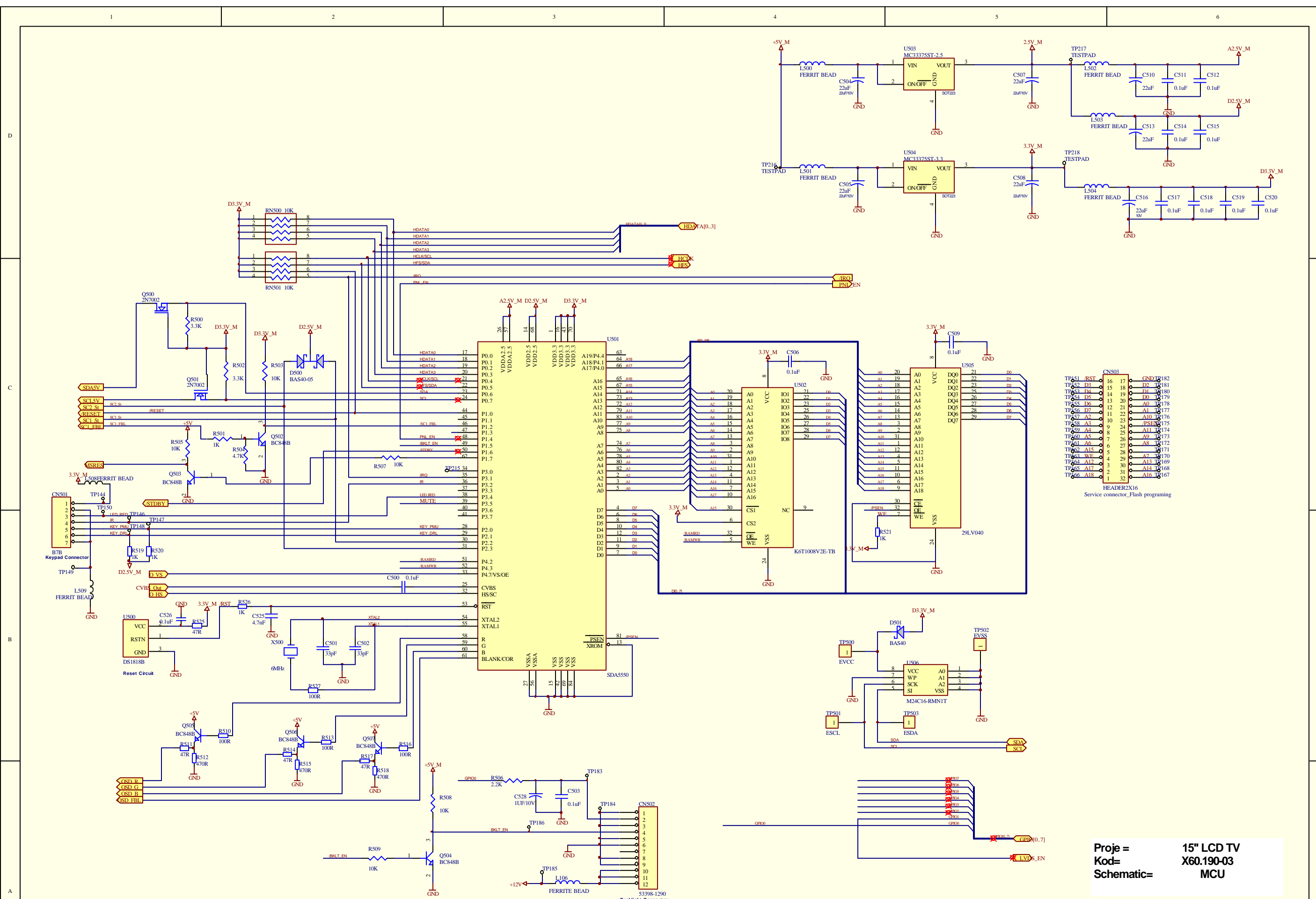

Proje = 15" LCD TV  
 Kod = X60.190-03  
 Schematic = MCU

Beko Elektronik A.S.		
Size C	Title 3. MCU	Rev A
Document Number	Control	
Date	24-Sep-2003	Sheet 5 of 9

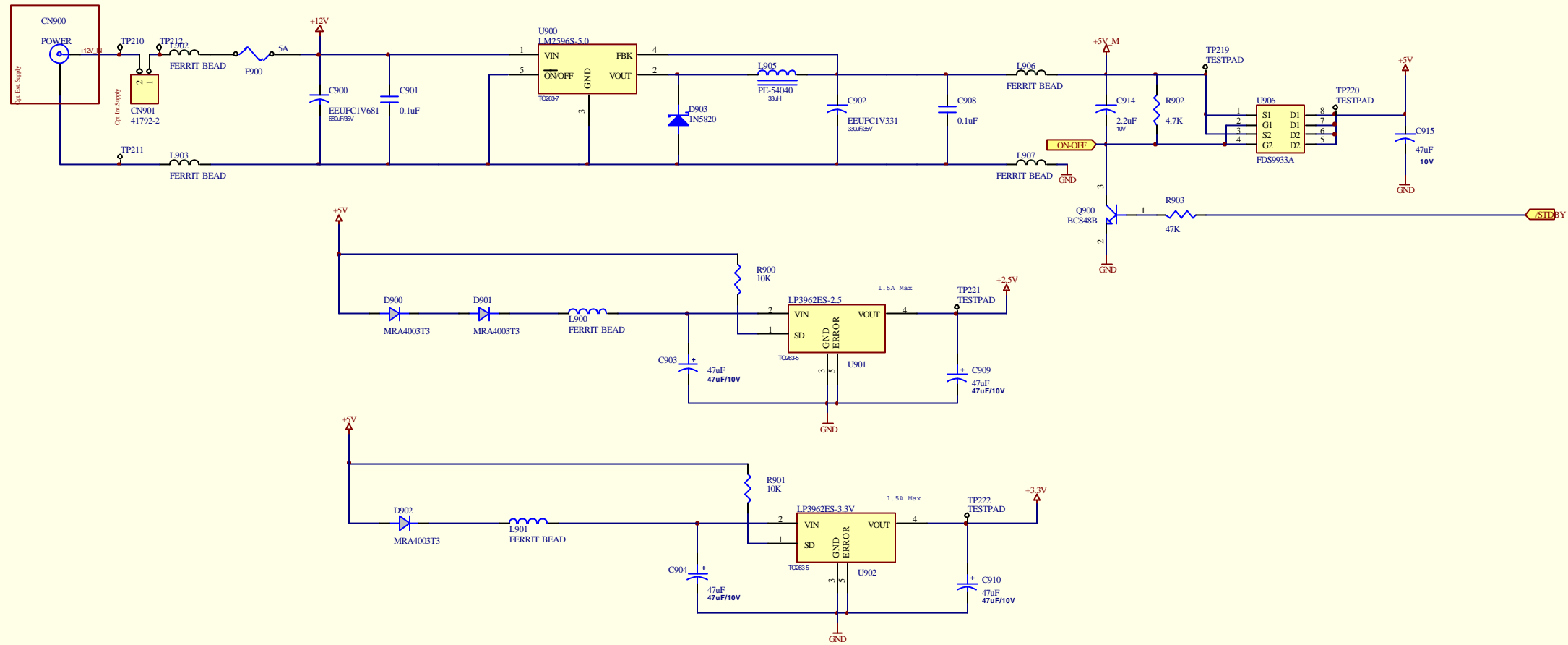

Proje = 15" LCD TV  
 Kod= X60.190-03  
 Schematic= POWER

Beko Elektronik A.S.		
Size C	Title 7. Power	Rev A
Document Number	Control	
Date 24-Sep-2003	Sheet 9	of 9

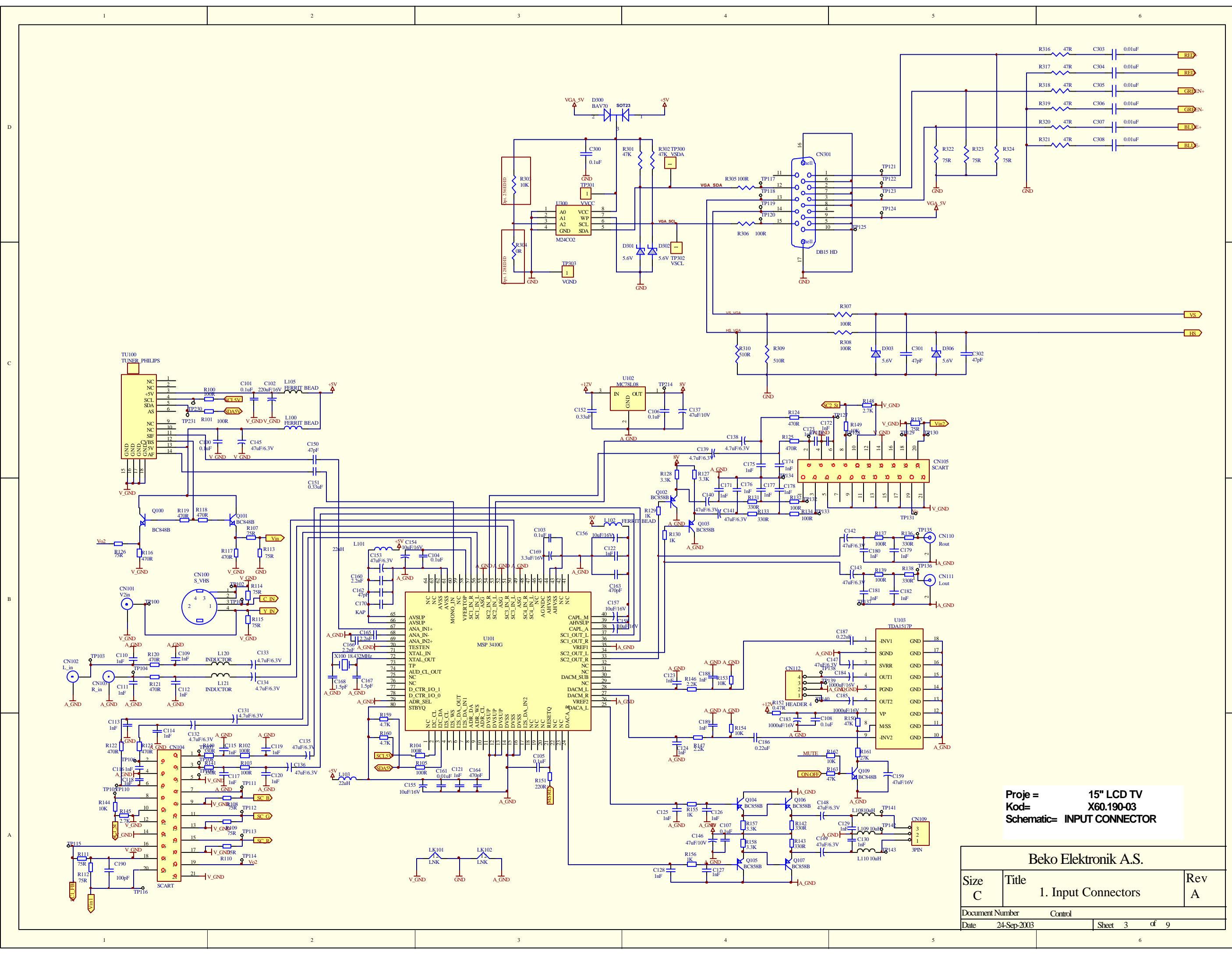

Proje = 15" LCD TV  
 Kod = X60.190-03  
 Schematic = INPUT CONNECTOR

Beko Elektronik A.S.		
Size C	Title 1. Input Connectors	Rev A
Document Number	Control	
Date 24-Sep-2003	Sheet 3	d' 9

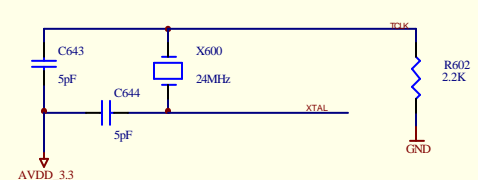
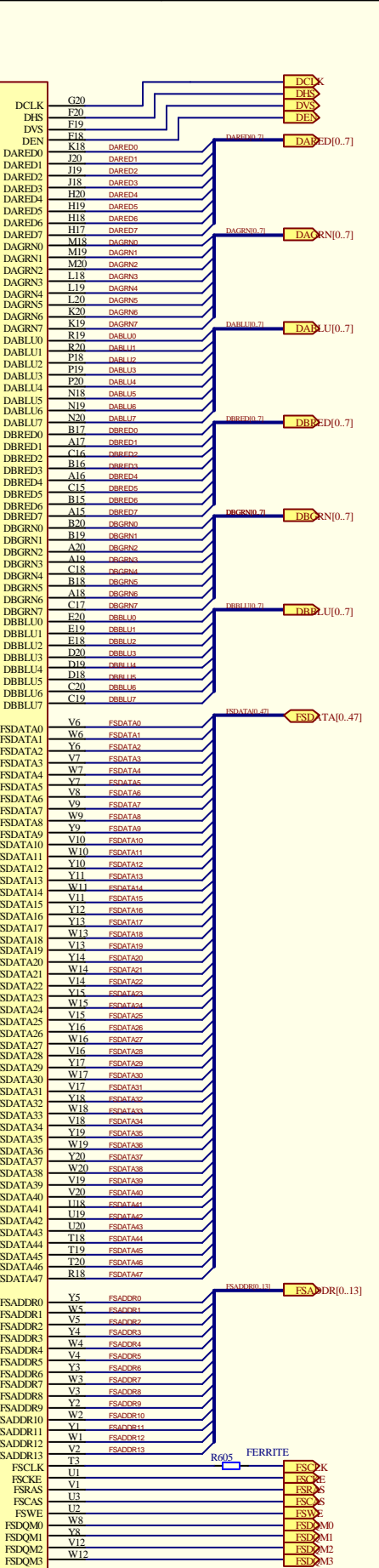
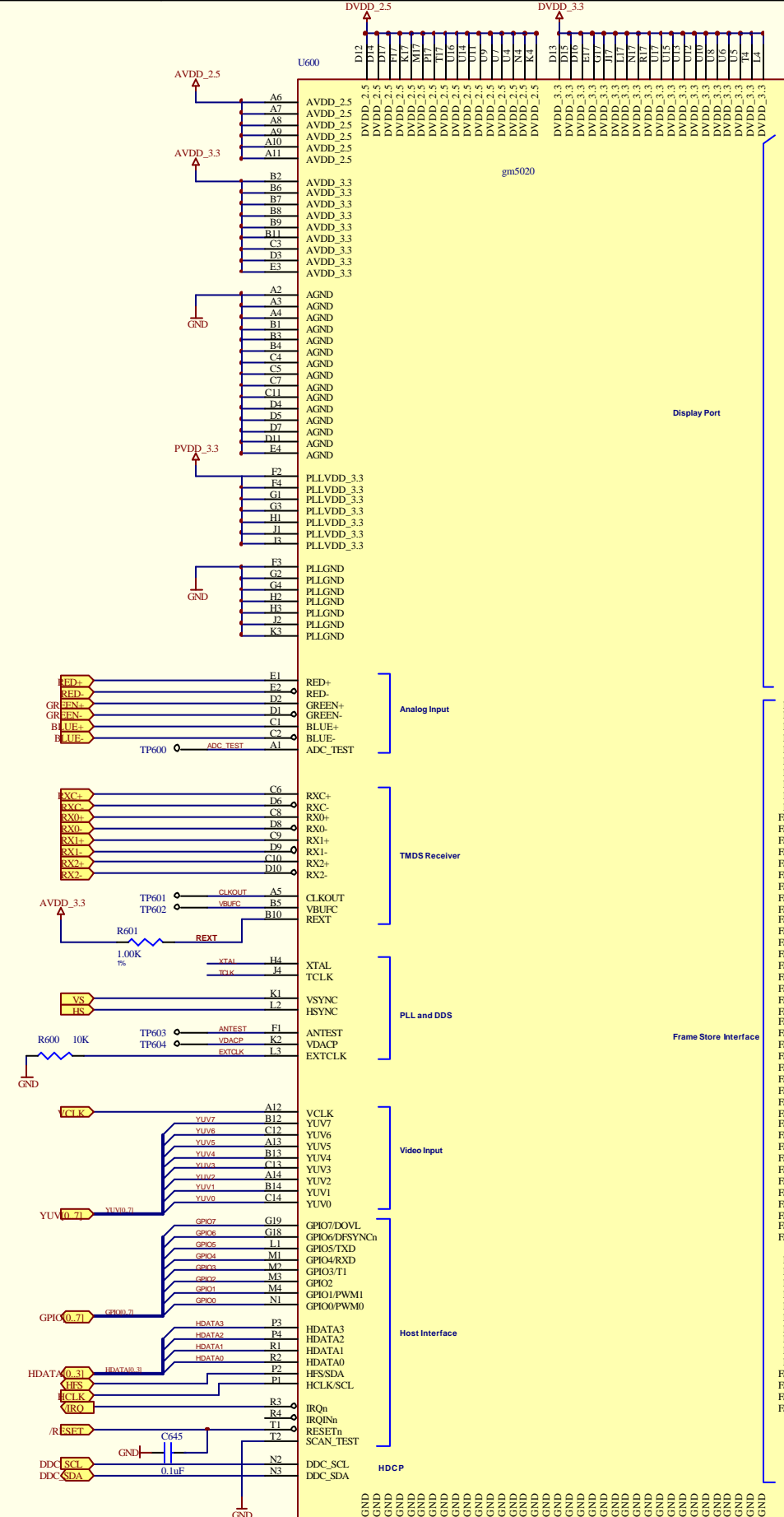
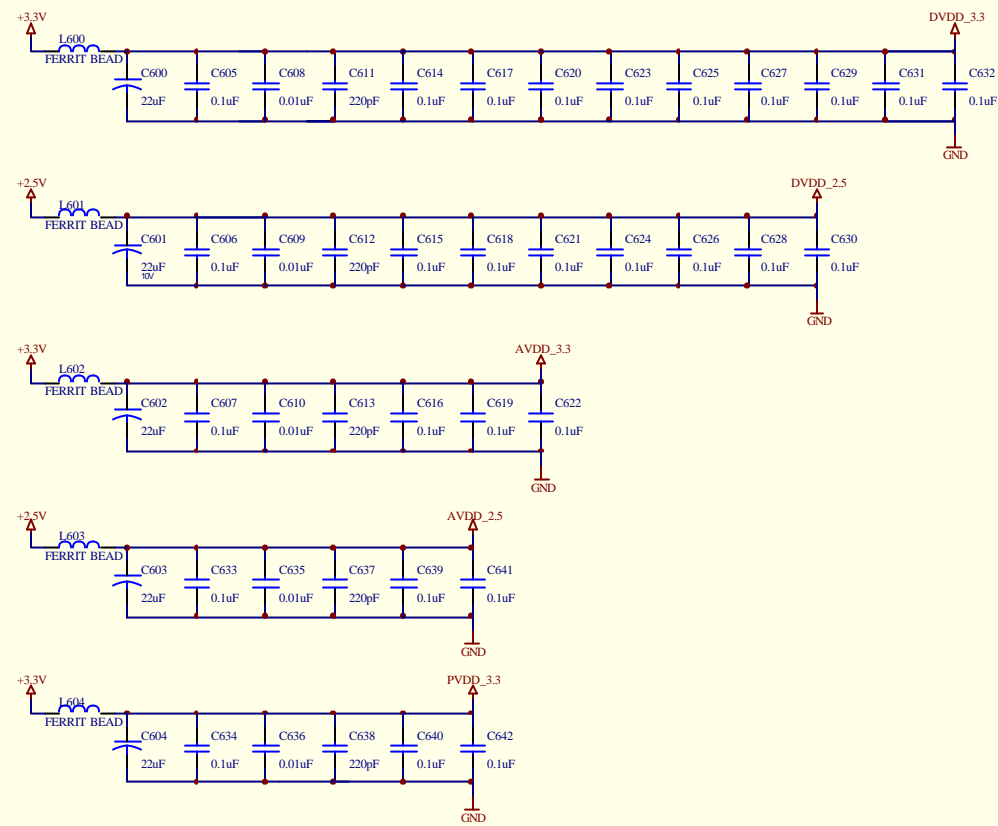

Proje = 15" LCD TV  
 Kod= X60.190-03  
 Schematic= GM5020

Beko Elektronik A.S.		
Size C	Title 4. gm5020	Rev A
Document Number	Control	
Date 24-Sep-2003	Sheet 6	d' 9

If you need more information on Computer and Electronic Repair, please visit these websites to improve yourself.

<http://www.fastrepairguide.com>

<http://www.protech2u.com>

<http://www.plasma-television-repair.com>

<http://www.lcd-television-repair.com>

Happy Repairing!!

### **Highly Recommended Repair Ebook:**

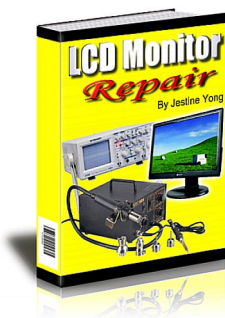

If you're a LCD Monitor repairer, then this is the best guide for you. Why? Because, the author revealed all his LCD Monitor Repairing secrets for you. I think, with just few Repair tips you learned from this guide you will get back your investment!

[Click Here to read](#) more.



This eBook will show you how to test the electronic component correctly and accurately. Some of you may say that I don't need this eBook because it is too simple! Do you know that, in fact there is lots of testing electronic components secrets I have learned from this guide? Do you know how to test a 'TRIAC' correctly and accurately? If you answer no then I guess you have to get this eBook. [Click Here to read more.](#)

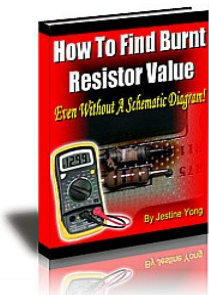

Are you tired of searching the service manuals to look for the value of a burnt resistor? If the answer is YES, then this eBook is a 'must have' guide for you. You can save a lot of time and be able to repair customer's Electronic equipment with burnt resistors in it.

[Click here to read more.](#)